

Note: The Land Pattern images are shown in the Nominal Density Level

Non-polarized Rectangular Chip Components

<p>Chip Capacitor</p> 	<p>Chip Resistor</p> 	<p>Chip Inductor</p> 
<p>Chip Varistor</p> 	<p>Chip Thermistor</p> 	<p>Chip Fuse</p> 
<p>Chip Non-polarized Diode</p> 	<p>Chip Filter</p> 	<p>Chip Ferrite Bead</p> 
<p>Chip Land Pattern Zero Rotation</p> 		

Polarized Rectangle Chip Components

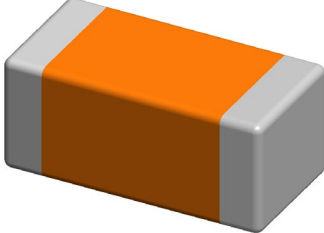
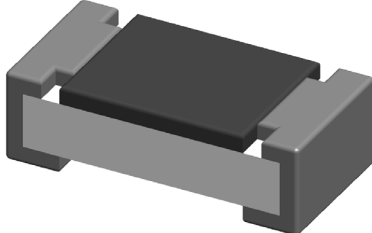
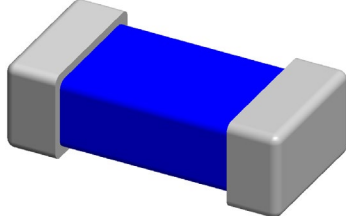
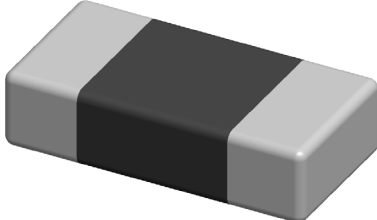
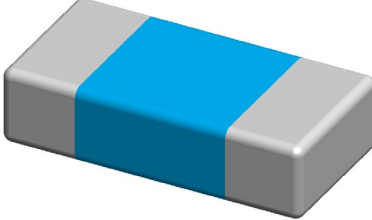
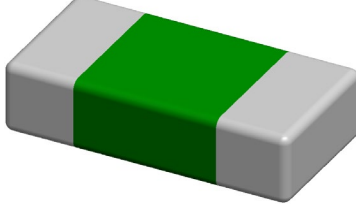
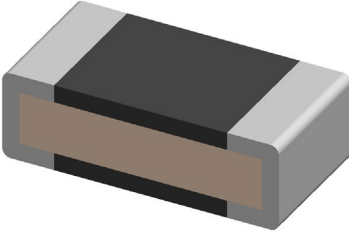
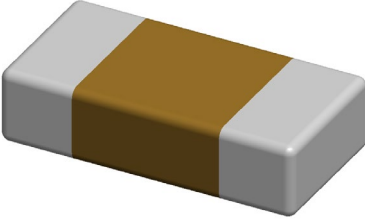
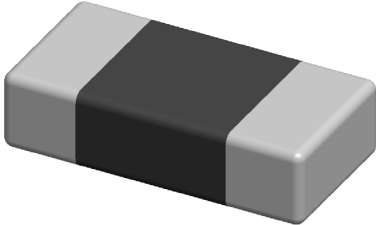
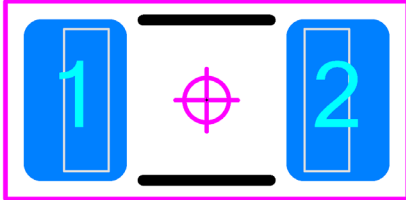
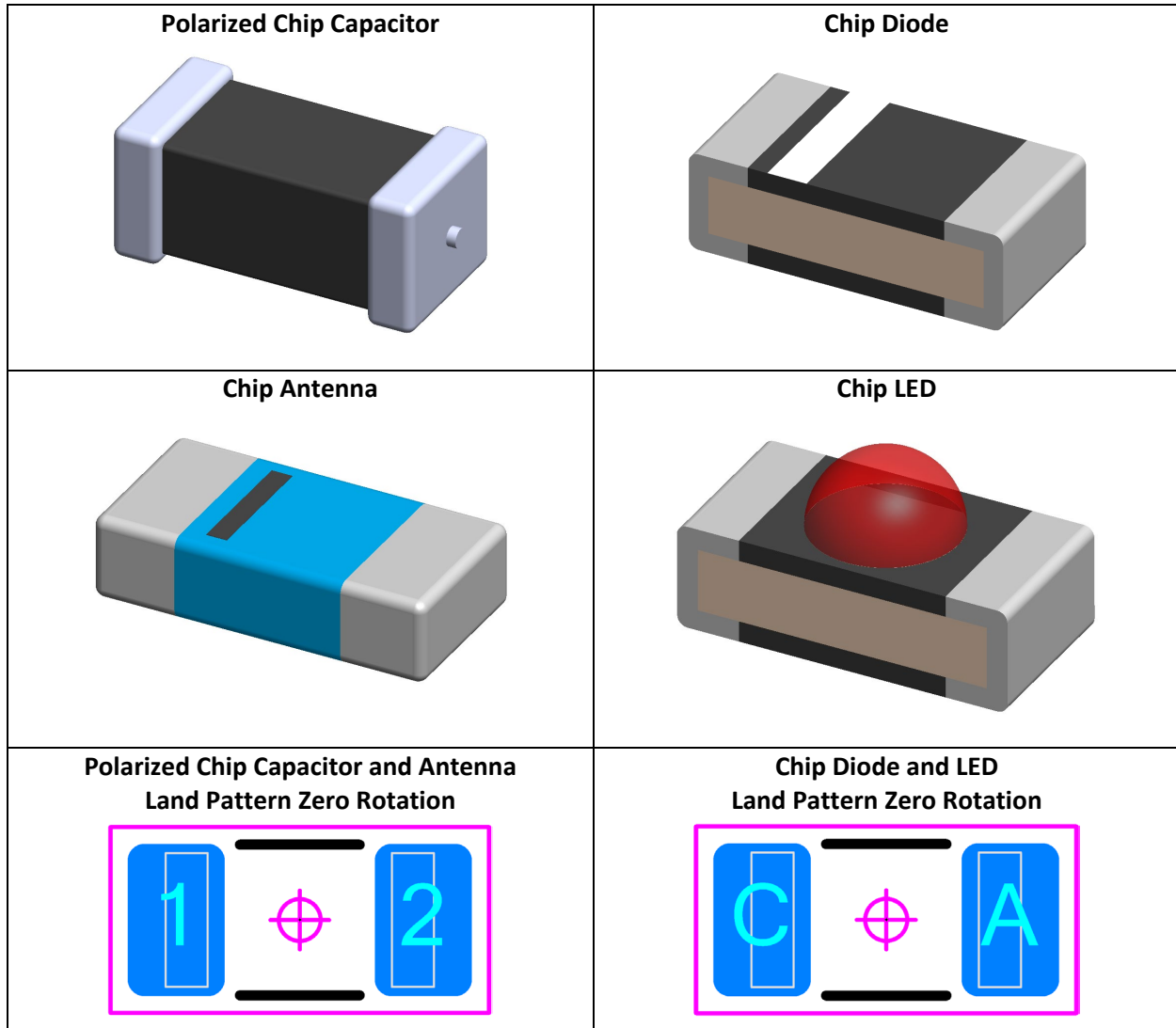

Rectangular Chip Components (unit: mm)

Chip Package Sizes	Rectangular End Cap	Least Density Level			
	Nominal Package Length	Toe	Heel	Side	Courtyard
2010 & Greater	Length > 4.75 mm	0.40	0.00	0.00	0.10
1812 & 1825	Length > 3.85 and <= 4.75 mm	0.30	0.00	0.00	0.10
1206, 1210 & 0612	Length > 2.85 and <= 3.85 mm	0.25	0.00	0.00	0.10
0603, 0705 & 0805	Length > 1.30 and <= 2.85 mm	0.20	0.00	0.00	0.10
0402, 0306 & 0502	Length > 0.75 and <= 1.30 mm	0.15	0.00	0.00	0.10
0201	Length > 0.50 and <= 0.75 mm	0.08	0.00	0.00	0.10
01005 & Less	Length <= 0.50 mm	0.04	0.00	0.00	0.10



Chip Package Sizes
2010 & Greater
1812 & 1825
1206, 1210 & 0612
0603, 0705 & 0805
0402, 0306 & 0502
0201
01005 & Less

Rectangular End Cap
Nominal Package Length
Length > 4.75 mm
Length > 3.85 and <= 4.75 mm
Length > 2.85 and <= 3.85 mm
Length > 1.30 and <= 2.85 mm
Length > 0.75 and <= 1.30 mm
Length > 0.50 and <= 0.75 mm
Length <= 0.50 mm

Nominal Density Level			
Toe	Heel	Side	Courtyard
0.50	0.00	0.00	0.20
0.40	0.00	0.00	0.20
0.35	0.00	0.00	0.20
0.30	0.00	0.00	0.20
0.20	0.00	0.00	0.15
0.10	0.00	0.00	0.15
0.05	0.00	0.00	0.15

Chip Package Sizes
2010 & Greater
1812 & 1825
1206, 1210 & 0612
0603, 0705 & 0805
0402, 0306 & 0502
0201
01005 & Less

Rectangular End Cap
Nominal Package Length
Length > 4.75 mm
Length > 3.85 and <= 4.75 mm
Length > 2.85 and <= 3.85 mm
Length > 1.30 and <= 2.85 mm
Length > 0.75 and <= 1.30 mm
Length > 0.50 and <= 0.75 mm
Length <= 0.50 mm



Most Density Level			
Toe	Heel	Side	Courtyard
0.60	0.00	0.05	0.40
0.50	0.00	0.05	0.40
0.45	0.00	0.05	0.40
0.40	0.00	0.05	0.40
0.25	0.00	0.00	0.20
0.12	0.00	0.00	0.20
0.06	0.00	0.00	0.20

Rectangular Chip Component Package Sizes

Table of Chip Package Size Codes and Dimensions			
EIA (inch) Name	Inch Dimensions	IEC (metric) Name	Metric Dimensions
01005	0.0157 in × 0.0079 in	0402	0.4 mm × 0.2 mm
0201	0.024 in × 0.012 in	0603	0.6 mm × 0.3 mm
0402	0.039 in × 0.020 in	1005	1.0 mm × 0.5 mm
0603	0.063 in × 0.031 in	1608	1.6 mm × 0.8 mm
0805	0.079 in × 0.049 in	2012	2.0 mm × 1.25 mm
1008	0.098 in × 0.079 in	2520	2.5 mm × 2.0 mm
1206	0.126 in × 0.063 in	3216	3.2 mm × 1.6 mm
1210	0.126 in × 0.098 in	3225	3.2 mm × 2.5 mm
1806	0.177 in × 0.063 in	4516	4.5 mm × 1.6 mm
1812	0.18 in × 0.13 in	4532	4.5 mm × 3.2 mm
2010	0.197 in × 0.098 in	5025	5.0 mm × 2.5 mm
2512	0.25 in × 0.13 in	6332	6.4 mm × 3.2 mm
2920	0.29 in × 0.20 in	7451	7.4 mm × 5.1 mm

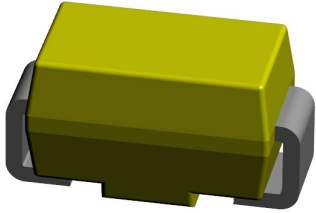
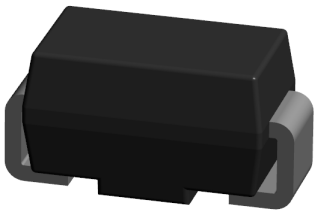

Non-polarized Molded Body Inward Flat Ribbon Components

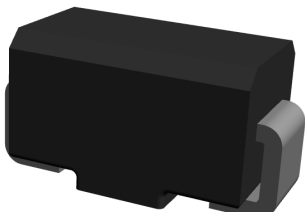
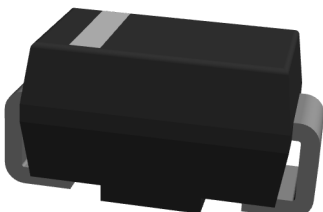
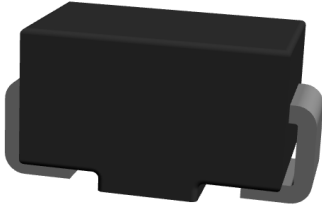
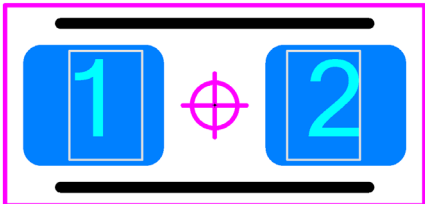
<p>Molded Capacitors (CAPM)</p> 	<p>Molded Non-polarized Diode (DIOMN)</p> 	<p>Molded Fuses (FUSM)</p> 
<p>Molded Body Inductor (INDM)</p> 	<p>Molded Polarized Inductor (INDPM)</p> 	<p>Molded Resistors (RESM)</p> 
<p>Molded Body Land Pattern Zero Rotation</p> 		

Polarized Molded Body Inward Flat Ribbon Components

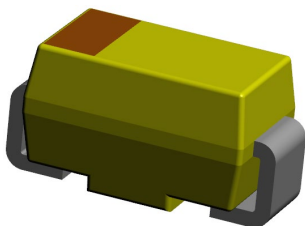
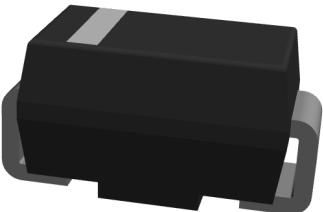
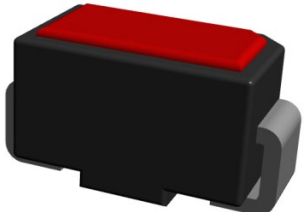
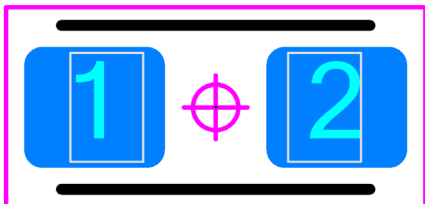
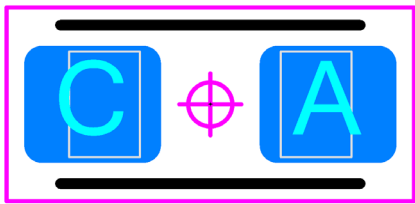
<p>Polarized Capacitor (CAPPM)</p> 	<p>Molded Body Diode (DIOM)</p> 	<p>Molded Body LED (LEDM)</p> 
<p>Polarized Capacitor Land Pattern Zero Rotation</p> 	<p>Diode and LED Land Pattern Zero Rotation</p> 	

Inward Flat Ribbon L-Leads (unit: mm)

Inward Flat Ribbon L
Maximum Package Height
Height > 4.20 mm
Height > 3.20 and <= 4.20 mm
Height > 2.20 and <= 3.20 mm
Height > 1.20 and <= 2.20 mm
Height <= 1.20 mm

Least Density Level			
Toe	Heel	Side	Courtyard
0.15	0.50	0.00	0.10
0.10	0.45	0.00	0.10
0.05	0.40	0.00	0.10
0.00	0.35	0.00	0.10
0.00	0.30	0.00	0.10

Inward Flat Ribbon L
Maximum Package Height
Height > 4.20 mm
Height > 3.20 and <= 4.20 mm
Height > 2.20 and <= 3.20 mm
Height > 1.20 and <= 2.20 mm
Height <= 1.20 mm

Nominal Density Level			
Toe	Heel	Side	Courtyard
0.20	0.60	0.00	0.20
0.15	0.55	0.00	0.20
0.10	0.50	0.00	0.20
0.05	0.45	0.00	0.20
0.00	0.40	0.00	0.20

Inward Flat Ribbon L
Maximum Package Height
Height > 4.20 mm
Height > 3.20 and <= 4.20 mm
Height > 2.20 and <= 3.20 mm
Height > 1.20 and <= 2.20 mm
Height <= 1.20 mm

Most Density Level			
Toe	Heel	Side	Courtyard
0.25	0.70	0.05	0.40
0.20	0.65	0.05	0.40
0.15	0.60	0.05	0.40
0.10	0.55	0.05	0.40
0.05	0.50	0.05	0.40

Common Molded Body Tantalum Capacitors			
EIA Size Code	Package Dimensions	KEMET Case Code	AVX Case Code
2012-12	2.0 mm × 1.3 mm × 1.2 mm	R	R
3216-10	3.2 mm × 1.6 mm × 1.0 mm	I	K
3216-12	3.2 mm × 1.6 mm × 1.2 mm	S	S
3216-18	3.2 mm × 1.6 mm × 1.8 mm	A	A
3528-12	3.5 mm × 2.8 mm × 1.2 mm	T	T
3528-21	3.5 mm × 2.8 mm × 2.1 mm	B	B
6032-15	6.0 mm × 3.2 mm × 1.5 mm	U	W
6032-28	6.0 mm × 3.2 mm × 2.8 mm	C	C
7260-38	7.3 mm × 6.0 mm × 3.8 mm	E	V
7343-20	7.3 mm × 4.3 mm × 2.0 mm	V	Y
7343-31	7.3 mm × 4.3 mm × 3.1 mm	D	D
7343-43	7.3 mm × 4.3 mm × 4.3 mm	X	E



Common Molded Body Diodes		
JEDEC Standard	Case Code	Package Dimensions
DO-214AA	SMB	5.30 mm × 3.60 mm × 2.25 mm
DO-214AB	SMC	7.95 mm × 5.90 mm × 2.25 mm
DO-214AC	SMA	5.20 mm × 2.60 mm × 2.15 mm

Metal Electrode Leadless Face (MELF)

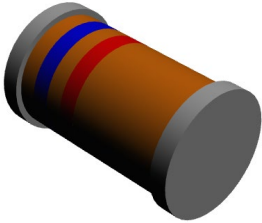
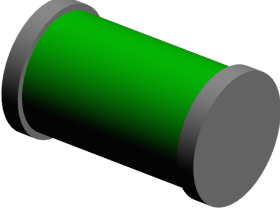
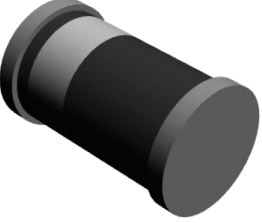
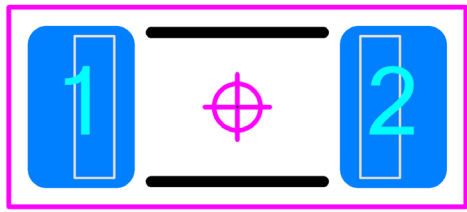
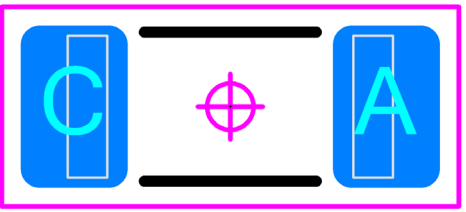
MELF Resistor (RESMELF)	MELF Fuse (FUSEMELF)	MELF Diode (DIOMELF)
		
Resistor and Fuse Land Pattern Zero Rotation 		MELF Diode Land Pattern Zero Rotation 

Metal Electrode Leadless Face (MELF) (unit: mm)

Lead Part	Most Density Level A	Nominal Density Level B	Least Density Level C
Toe (J_T)	0.60	0.40	0.20
Heel (J_H)	0.20	0.10	0.02
Side (J_S)	0.10	0.05	0.01
Round-off factor	Round off to the nearest two place decimal, i.e., 1.00, 1.01, 1.02, 1.03		
Courtyard excess	0.40	0.20	0.10

Common MELF Package Sizes		
Common Case Names	Size Code	Package Dimensions
MicroMelf (MMU)	0102	2.20 mm L X 1.10 mm Dia.
MiniMelf (MMA)	0204	3.60 mm L X 1.40 mm Dia.
Melf (MMB)	0207	5.80 mm L X 2.20 mm Dia.

Small Outline Diode (SOD) with Gull-Wing Leads

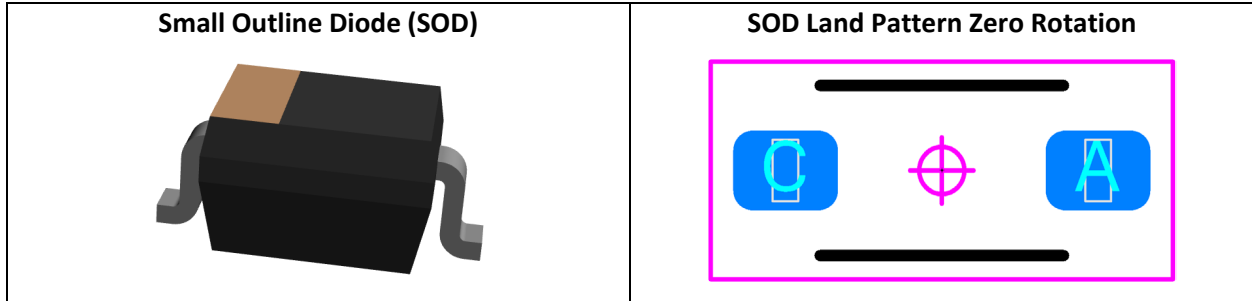

Flat Ribbon L and Gull-Wing Leads (unit: mm)

Lead Part	Most Density Level A	Nominal Density Level B	Least Density Level C
Toe (J_T)	0.30	0.25	0.20
Heel (J_H) ¹	0.40	0.35	0.30
Side (J_S)	0.07	0.06	0.05
Round-off factor	Round off to the nearest two place decimal, i.e., 1.00, 1.01, 1.02, 1.03		
Courtyard excess	0.40	0.20	0.10

Common Small Outline Diode (SOD) Sizes	
Case Code	Package Dimensions
SOD-123	3.68 mm × 1.17 mm × 1.60 mm
SOD-128	5.00 mm × 2.70 mm × 1.10 mm
SOD-323	1.70 mm × 1.25 mm × 0.95 mm
SOD-523	1.25 mm × 0.85 mm × 0.65 mm
SOD-723	1.40 mm × 0.60 mm × 0.59 mm

Small Outline Diode Flat Lead (SODFL)

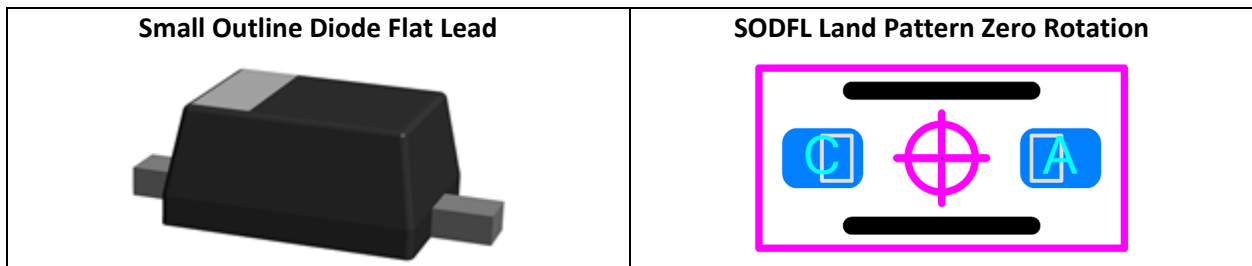

Small Outline Diodes, Flat Lead (unit: mm)

Lead Part	Most Density Level A	Nominal Density Level B	Least Density Level C
Toe (J_T)	0.30	0.20	0.10
Heel (J_H)	0.00	0.00	0.00
Side (J_S)	0.05	0.00	0.00
Round-off factor	Round off to the nearest two place decimal, i.e., 1.00, 1.01, 1.02, 1.03		
Courtyard excess	0.40	0.20	0.10

Capacitor, Aluminum Electrolytic (CAPAE)

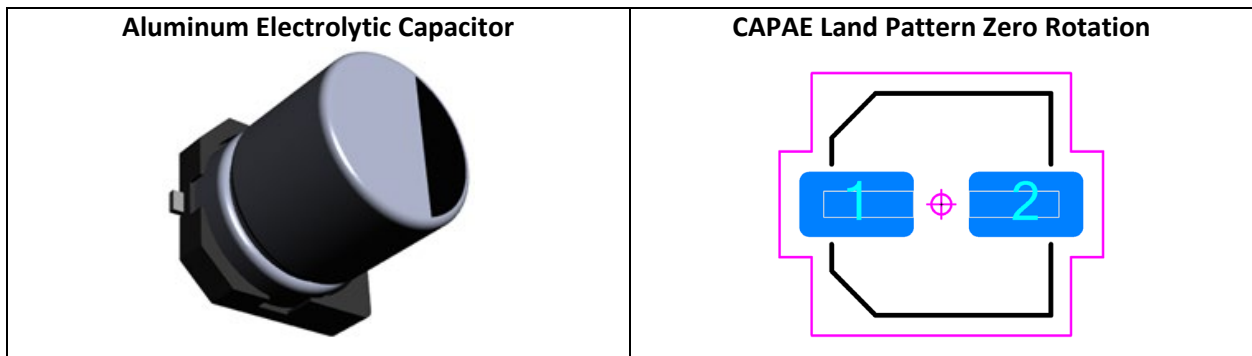

Crystals (XTAL)

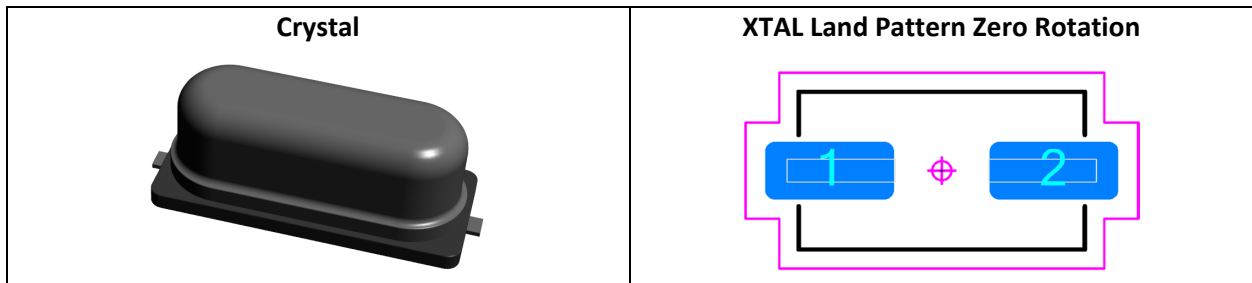

Electrolytic Aluminum Capacitor and Crystal (unit: mm)

Lead Part	Most Density Level A	Nominal Density Level B	Least Density Level C
Toe (J_T)	0.70	0.50	0.30
10.00 mm or higher	1.00	0.70	0.40
Heel (J_H)	0.05	0.00	0.00
10.00 mm or higher	0.10	0.00	0.00
Side (J_S)	0.50	0.40	0.30
10.00 mm or higher	0.60	0.50	0.40
Round-off factor	Round off to the nearest two place decimal, i.e., 1.00, 1.01, 1.02, 1.03		
Courtyard < 10.00 mm	0.40	0.20	0.10
Courtyard > 10.00 mm	0.80	0.40	0.20

Non-polarized Side Concave Packages 2-pin

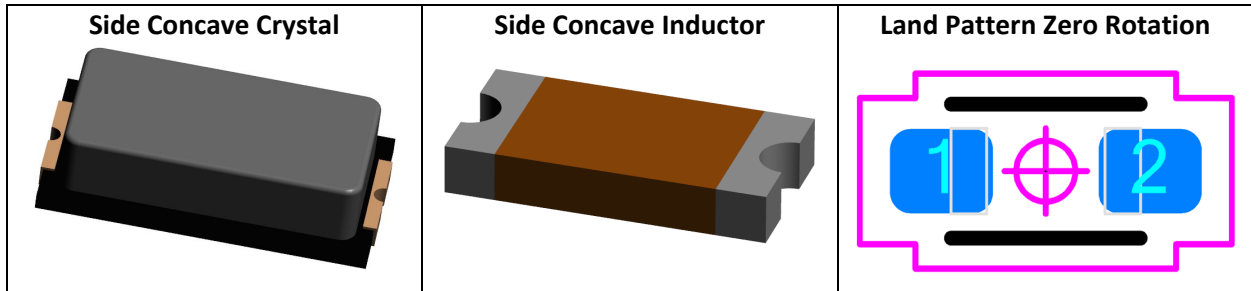

Polarized Side Concave Packages 2-pin

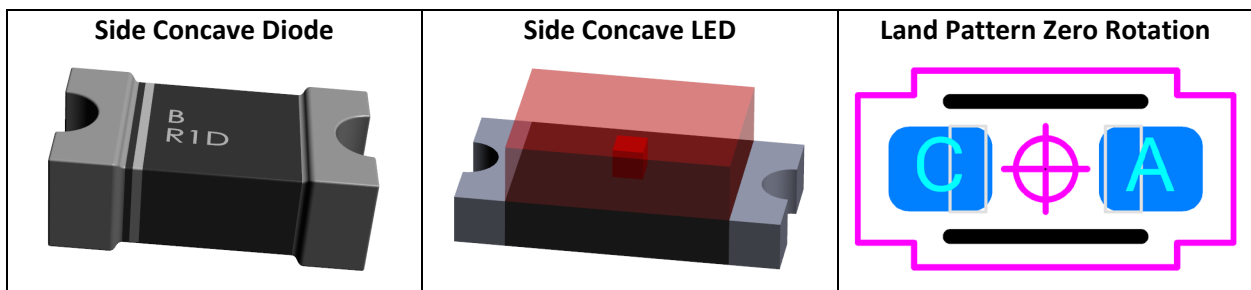

Side Concave Terminal (unit: mm)

Lead Part	Most Density Level A	Nominal Density Level B	Least Density Level C
Toe (J_T)	0.45	0.35	0.25
Heel (J_H)	0.00	0.00	0.00
Side (J_S)	0.00	0.00	0.00
Round-off factor	Round off to the nearest two place decimal, i.e., 1.00, 1.01, 1.02, 1.03		
Courtyard excess	0.40	0.20	0.10

Non-polarized Dual Flat No-Lead (DFN) 2-pin

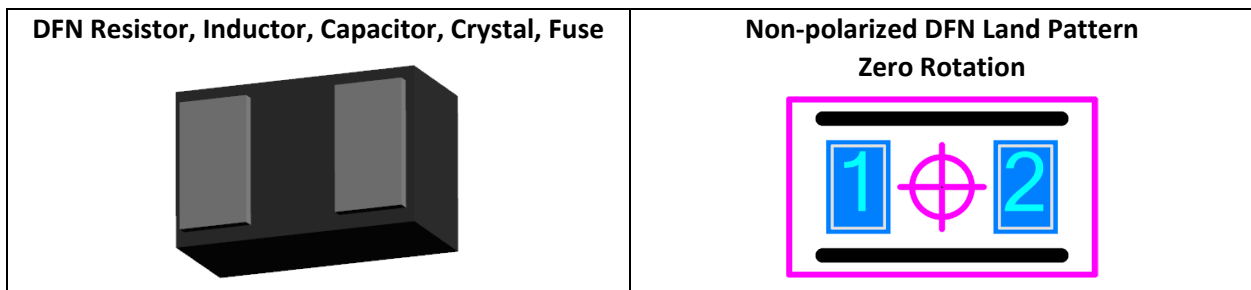

Polarized Dual Flat No-Lead (DFN) 2-pin

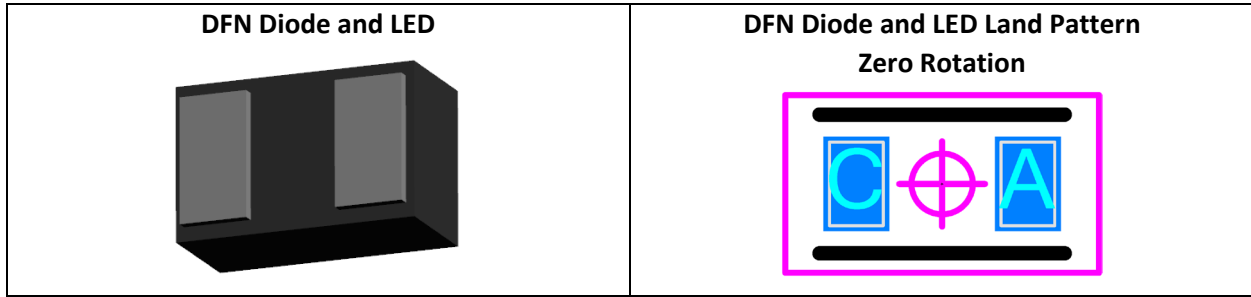

2-Pin Dual Flat No-Lead (DFN) (unit: mm)

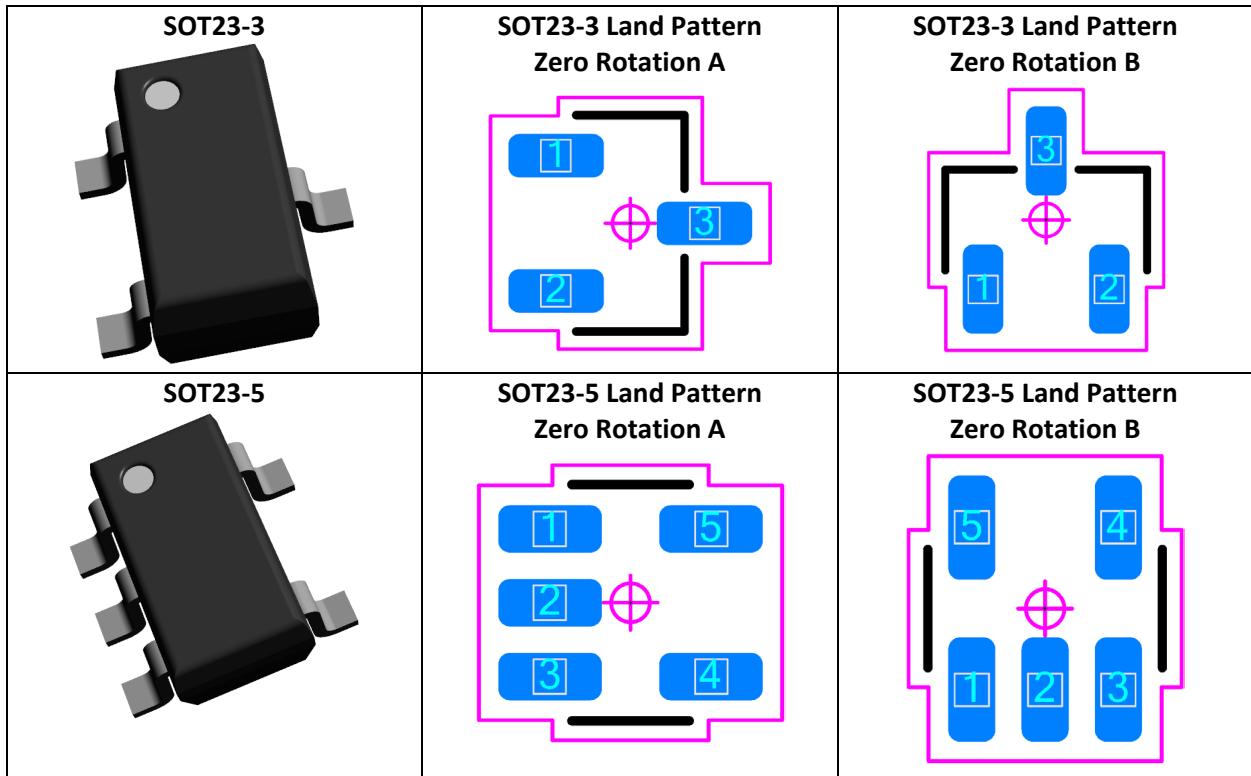

Lead Part	Most Density Level A	Nominal Density Level B	Least Density Level C
Periphery	0.05	0.00	0.00
Round-off factor	Round off to the nearest two place decimal, i.e., 1.00, 1.01, 1.02, 1.03		
Courtyard excess	0.40	0.20	0.10
Dual Flat No-Lead (DFN) Less than 1608 (0603)			
Periphery	0.00	0.00	0.00
Round-off factor	Round off to the nearest two place decimal, i.e., 1.00, 1.01, 1.02, 1.03		
Courtyard excess	0.20	0.15	0.10

Small Outline Transistor SOT23 (SOT)

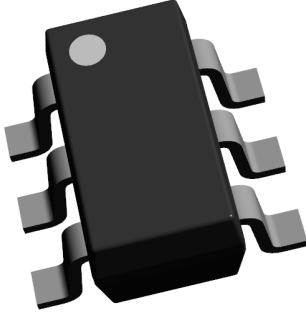
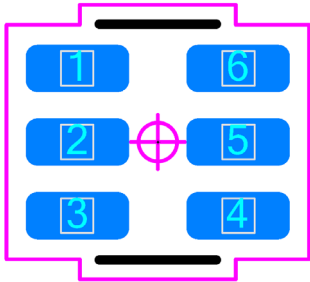
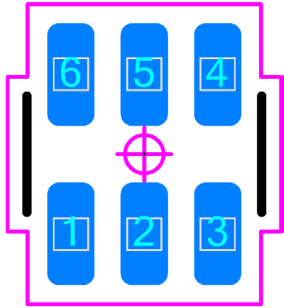
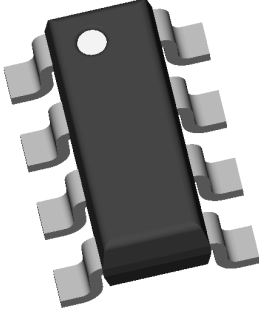
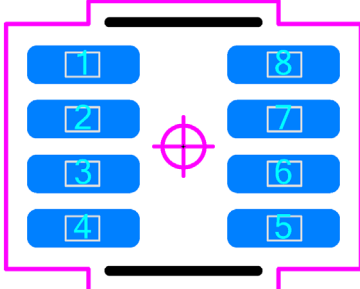
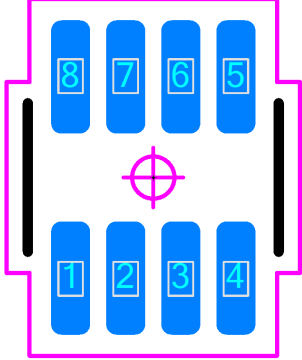

<p>SOT23-6</p> 	<p>SOT23-6 Land Pattern Zero Rotation A</p> 	<p>SOT23-6 Land Pattern Zero Rotation B</p> 
<p>SOT23-8</p> 	<p>SOT23-8 Land Pattern Zero Rotation A</p> 	<p>SOT23-8 Land Pattern Zero Rotation B</p> 

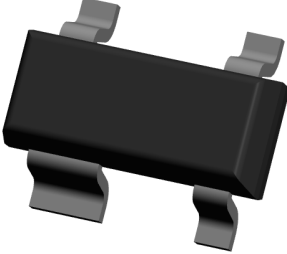
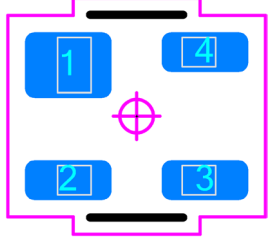
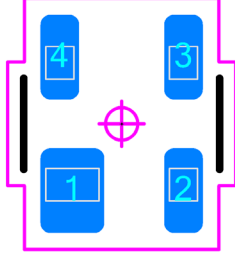
Small Outline Transistor SOT143 (SOT)

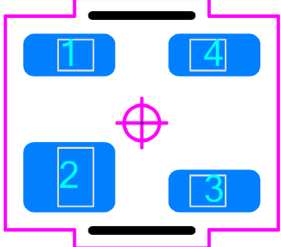
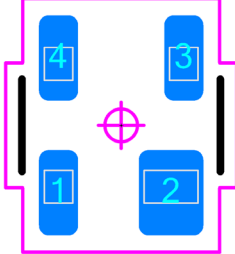
<p>SOT143</p> 	<p>SOT143 Land Pattern Zero Rotation A</p> 	<p>SOT143 Land Pattern Zero Rotation B</p> 
<p>SOT143 Reverse</p> 	<p>SOT143R Land Pattern Zero Rotation A</p> 	<p>SOT143R Land Pattern Zero Rotation B</p> 

Small Outline Transistor SOT223-4 (SOT)

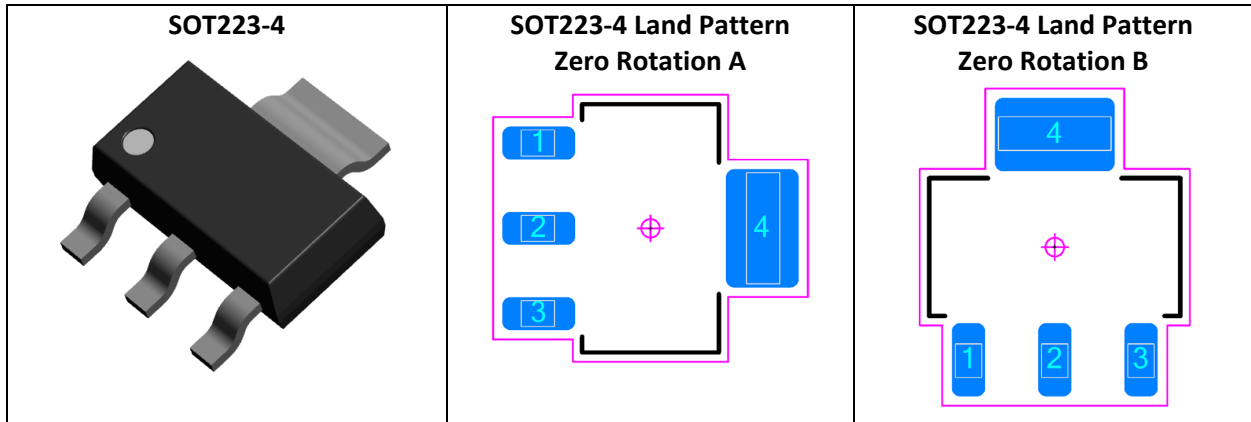

Small Outline Transistor SOT223-5 (SOT)

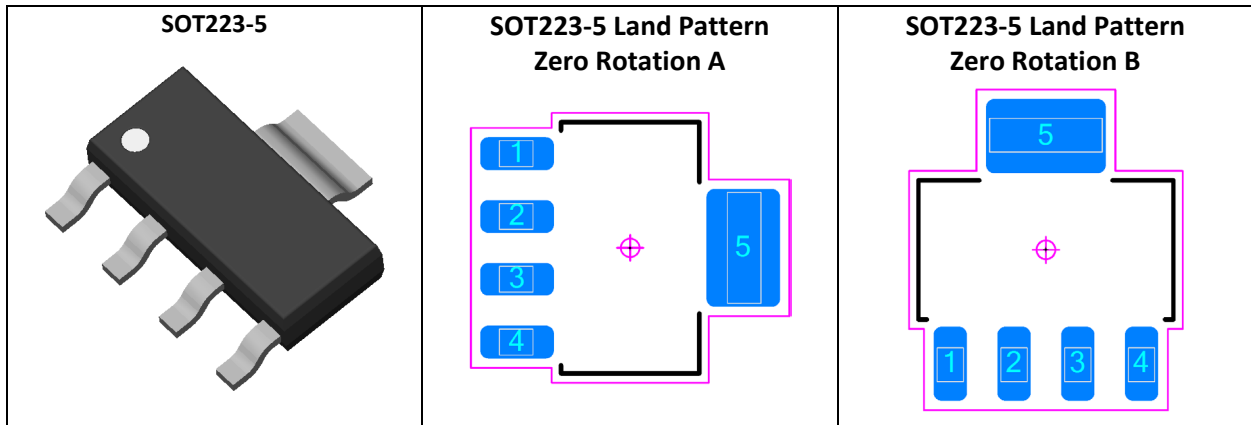

Small Outline Transistor SOT223-6 (SOT)

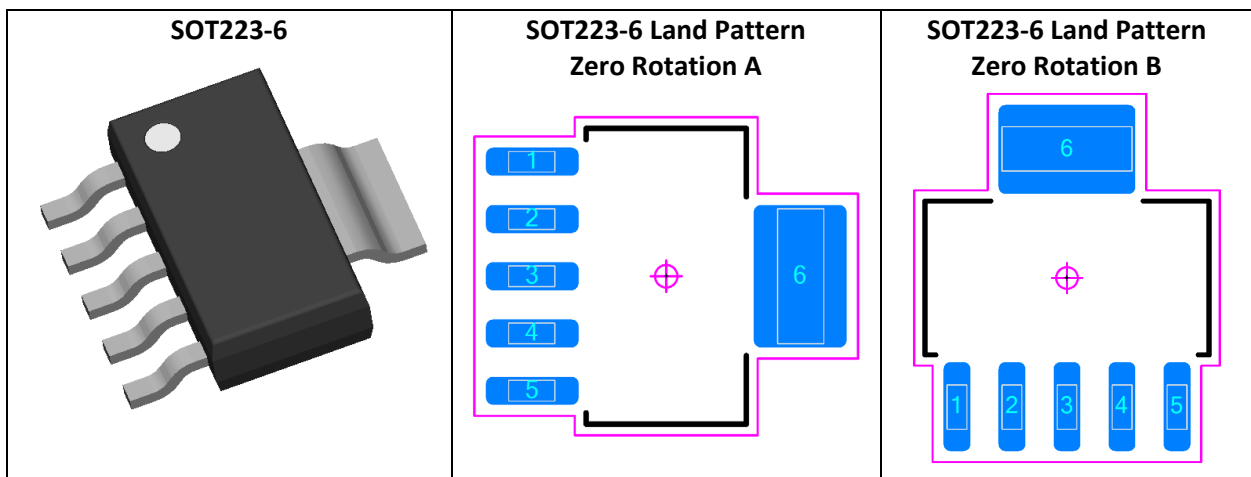

SOT Flat Ribbon and Gull-Wing Leads (unit: mm)

SOT's
Terminal Lead Spacing
Pitch > 1.92 mm
Pitch > 0.95 and <= 1.92 mm
Pitch > 0.65 and <= 0.95 mm
Pitch > 0.50 and <= 0.65 mm
Pitch > 0.40 and <= 0.50 mm
Pitch <= 0.40 mm

Least Density Level			
Toe	Heel	Side	Courtyard
0.20	0.30	0.05	0.10
0.15	0.20	0.04	0.10
0.15	0.20	0.03	0.10
0.10	0.15	0.01	0.10
0.10	0.15	0.00	0.10
0.10	0.15	0.00	0.10

SOT's
Terminal Lead Spacing
Pitch > 1.92 mm
Pitch > 0.95 and <= 1.92 mm
Pitch > 0.65 and <= 0.95 mm
Pitch > 0.50 and <= 0.65 mm
Pitch > 0.40 and <= 0.50 mm
Pitch <= 0.40 mm

Nominal Density Level			
Toe	Heel	Side	Courtyard
0.25	0.35	0.06	0.20
0.20	0.25	0.05	0.20
0.20	0.25	0.04	0.20
0.15	0.20	0.02	0.20
0.15	0.20	0.00	0.20
0.15	0.20	0.00	0.20





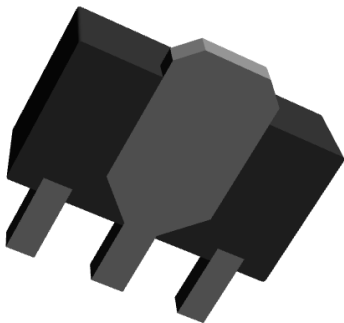
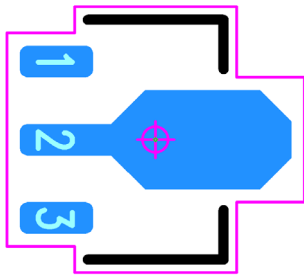
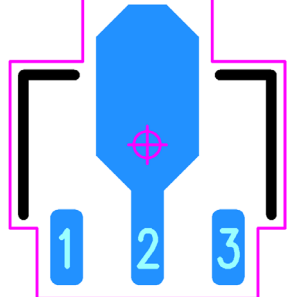

SOT's
Terminal Lead Spacing
Pitch > 1.92 mm
Pitch > 0.95 and <= 1.92 mm
Pitch > 0.65 and <= 0.95 mm
Pitch > 0.50 and <= 0.65 mm
Pitch > 0.40 and <= 0.50 mm
Pitch <= 0.40 mm

Most Density Level			
Toe	Heel	Side	Courtyard
0.30	0.40	0.07	0.40
0.25	0.30	0.06	0.40
0.25	0.30	0.05	0.40
0.20	0.25	0.03	0.40
0.20	0.25	0.00	0.40
0.20	0.25	0.00	0.40

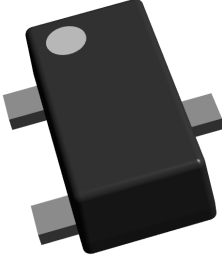
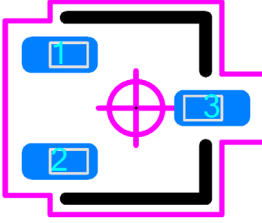
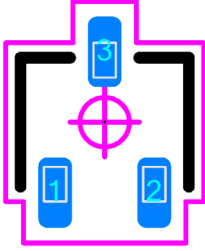
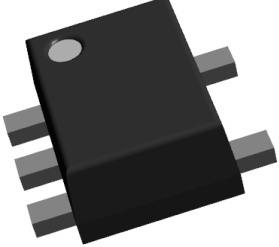
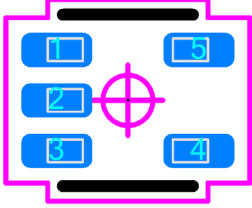
Small Outline Transistor SOT89 (SOT)

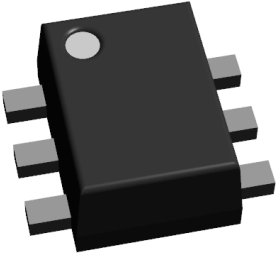
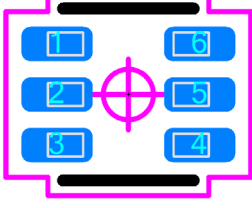
SOT89	SOT89 Land Pattern Zero Rotation A	SOT89 Land Pattern Zero Rotation B
		

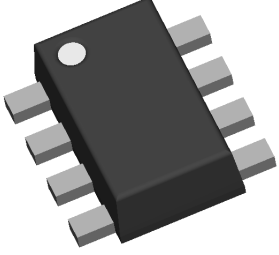
Small Outline Flat Lead (SOFL)

<p>SOTFL 3-Pin</p> 	<p>SOTFL 3-Pin Land Pattern Zero Rotation A</p> 	<p>SOTFL 3-Pin Land Pattern Zero Rotation B</p> 
<p>SOTFL 5-Pin</p> 	<p>SOTFL 5-Pin Land Pattern Zero Rotation A</p> 	<p>SOTFL 5-Pin Land Pattern Zero Rotation B</p> 
<p>SOTFL 6-Pin</p> 	<p>SOTFL 6-Pin Land Pattern Zero Rotation A</p> 	<p>SOTFL 6-Pin Land Pattern Zero Rotation B</p> 
<p>SOTFL 8-Pin</p> 	<p>SOTFL 8-Pin Land Pattern Zero Rotation A</p> 	<p>SOTFL 8-Pin Land Pattern Zero Rotation B</p> 

Small Outline Components, Flat Lead (unit: mm)

Lead Part	Most Density Level A	Nominal Density Level B	Least Density Level C
Toe (J_T)	0.30	0.20	0.10
Heel (J_H)	0.00	0.00	0.00
Side (J_S)	0.05	0.00	0.00
Round-off factor	Round off to the nearest two place decimal, i.e., 1.00, 1.01, 1.02, 1.03		
Courtyard excess	0.40	0.20	0.10



DPAK

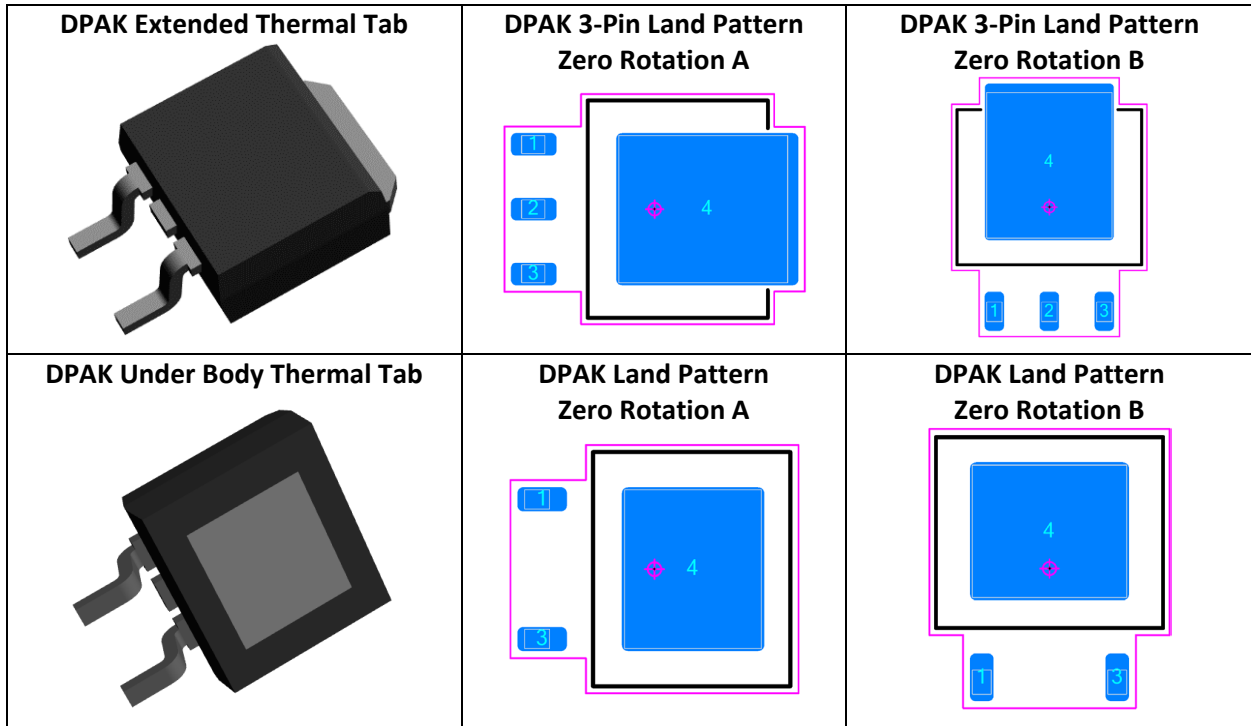

DPAK Flat Ribbon and Gull-Wing Leads (unit: mm)

DPAK's
Terminal Lead Spacing
Pitch > 2.54 mm
Pitch > 2.29 and <= 2.54 mm
Pitch > 1.70 and <= 2.29 mm
Pitch > 1.27 and <= 1.70 mm
Pitch <= 1.27 mm

Least Density Level			
Toe	Heel	Side	Courtyard
0.35	0.40	0.15	0.10
0.35	0.40	0.10	0.10
0.25	0.40	0.05	0.10
0.20	0.35	0.00	0.10
0.15	0.30	0.00	0.10

DPAK's
Terminal Lead Spacing
Pitch > 2.54 mm
Pitch > 2.29 and <= 2.54 mm
Pitch > 1.70 and <= 2.29 mm
Pitch > 1.27 and <= 1.70 mm
Pitch <= 1.27 mm

Nominal Density Level			
Toe	Heel	Side	Courtyard
0.45	0.50	0.20	0.20
0.45	0.50	0.15	0.20
0.35	0.50	0.10	0.20
0.30	0.45	0.05	0.20
0.25	0.40	0.05	0.20

Terminal Lead Spacing
Pitch > 2.54 mm
Pitch > 2.29 and <= 2.54 mm
Pitch > 1.70 and <= 2.29 mm
Pitch > 1.27 and <= 1.70 mm
Pitch <= 1.27 mm

Most Density Level			
Toe	Heel	Side	Courtyard
0.55	0.60	0.30	0.40
0.55	0.60	0.25	0.40
0.45	0.60	0.20	0.40
0.40	0.55	0.10	0.40
0.35	0.50	0.10	0.40

Transistor, Dual Flat No-lead (TRXDFN)

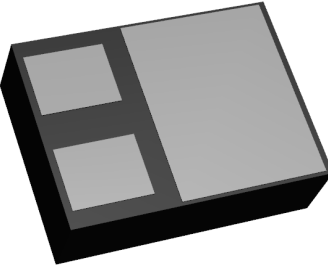
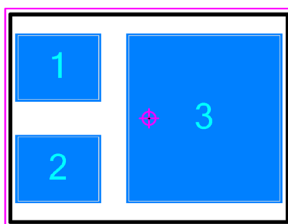
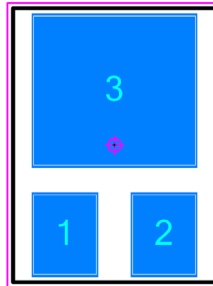
<p>Transistor DFN 3-Pin</p> 	<p>DFN 3-Pin Land Pattern Zero Rotation A</p> 	<p>DFN 3-Pin Land Pattern Zero Rotation B</p> 
----------------------------------------------------------------------------------------------------------------------	----------------------------------------------------------------------------------------------------------------------------------------	------------------------------------------------------------------------------------------------------------------------------------------

Oscillator, Dual Flat No-lead (OSCDFN)

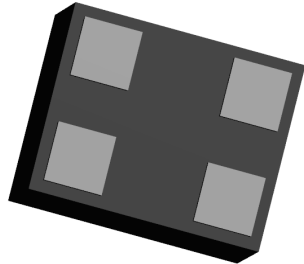
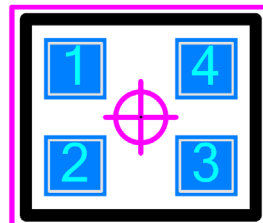
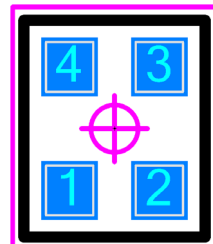
<p>Oscillator DFN 4-Pin</p> 	<p>DFN 4-Pin Land Pattern Zero Rotation A</p> 	<p>DFN 4-Pin Land Pattern Zero Rotation B</p> 
------------------------------------------------------------------------------------------------------------------------	------------------------------------------------------------------------------------------------------------------------------------------	--------------------------------------------------------------------------------------------------------------------------------------------

Dual Flat No-lead (DFN) (unit: mm)

Lead Part	Most Density Level A	Nominal Density Level B	Least Density Level C
Periphery	0.05	0.00	0.00
Round-off factor	Round off to the nearest two place decimal, i.e., 1.00, 1.01, 1.02, 1.03		
Courtyard excess	0.40	0.20	0.10
Dual Flat No-Lead (DFN) Less than 1608 (0603)			
Periphery	0.00	0.00	0.00
Round-off factor	Round off to the nearest two place decimal, i.e., 1.00, 1.01, 1.02, 1.03		
Courtyard excess	0.20	0.15	0.10



Oscillator, J-Lead (OSCJ)

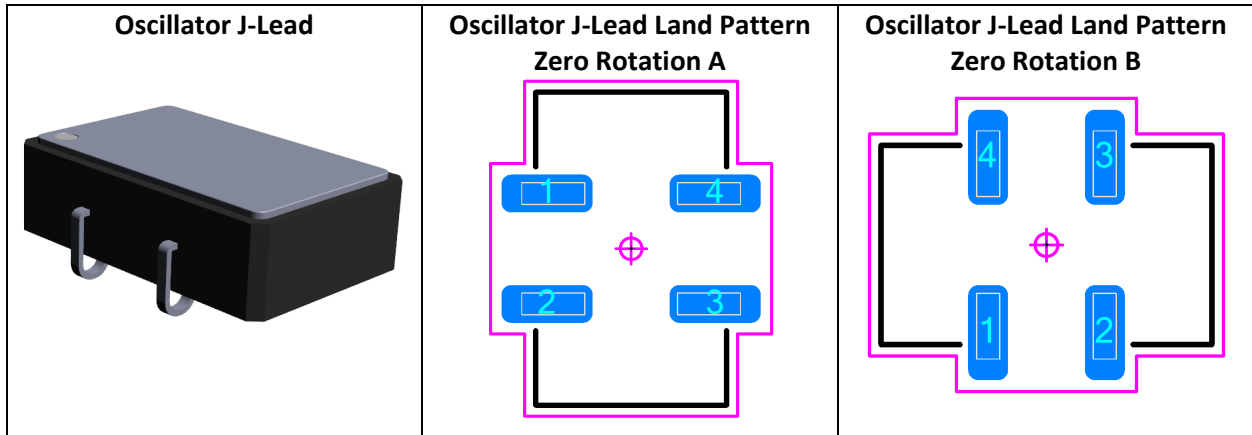

J-Leads (unit: mm)

Lead Part	Most Density Level A	Nominal Density Level B	Least Density Level C
Heel (J_H) (to find Z dim)	0.55	0.35	0.15
Toe (J_T) (to find G dim)	0.10	0.00	0.00
Side (J_S)	0.05	0.03	0.01
Round-off factor	Round off to the nearest two place decimal, i.e., 1.00, 1.01, 1.02, 1.03		
Courtyard excess	0.40	0.20	0.10

Oscillator, L-Lead (OSCL)

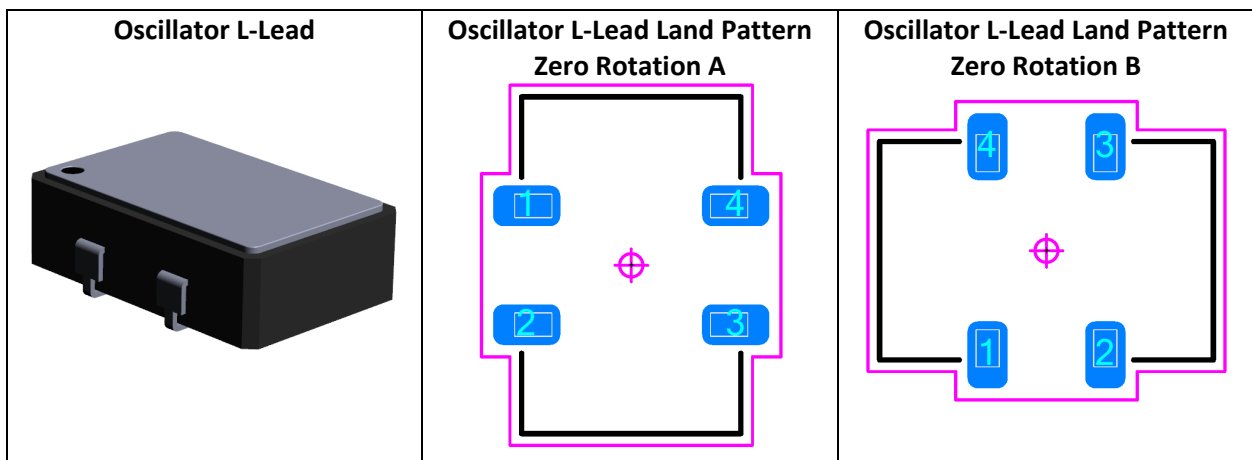

Oscillator Inward Flat Ribbon L Lead (unit: mm)

Lead Part	Most Density Level A	Nominal Density Level B	Least Density Level C
Toe (J_T) (to find G dim)	0.10	0.00	0.00
Heel (J_H) (to find Z dim)	0.60	0.50	0.40
Side (J_S)	0.07	0.06	0.05
Round-off factor	Round off to the nearest two place decimal, i.e., 1.00, 1.01, 1.02, 1.03		
Courtyard excess	0.40	0.20	0.10

Oscillator, Corner Concave (OSCCC)

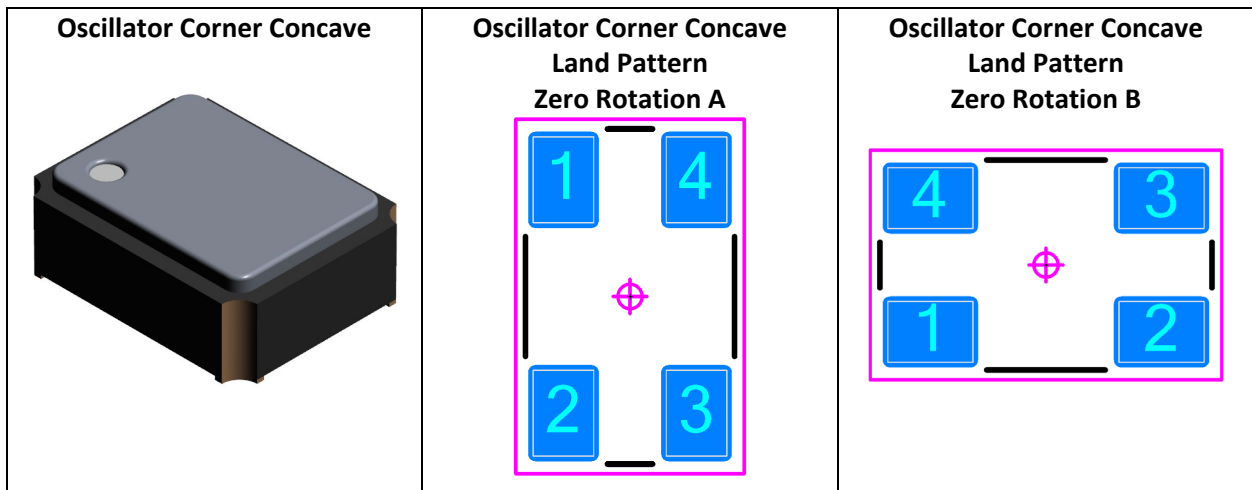

Corner Concave Component Oscillator Lead Package (unit: mm)

Lead Part	Most Density Level A	Nominal Density Level B	Least Density Level C
Outer Periphery ¹	0.20	0.15	0.10
Inner Periphery ²	0.00	0.00	0.00
Round-off factor	Round off to the nearest two place decimal, i.e., 1.00, 1.01, 1.02, 1.03		
Courtyard excess	0.40	0.20	0.10

Note 1. The edge of the land associated with the outside of the component body.

Note 2. The edge of the land under the component body.

Oscillator, Side Concave (OSCS)

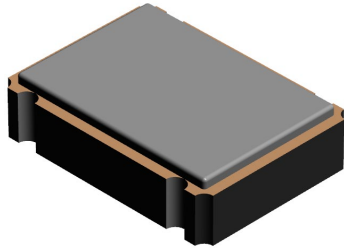
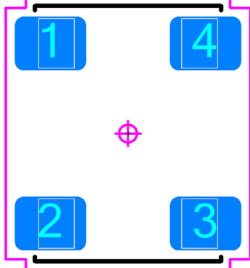
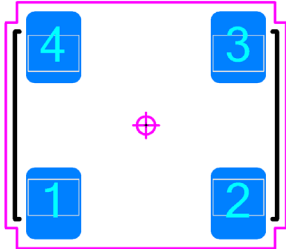
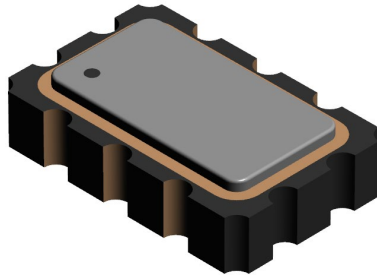
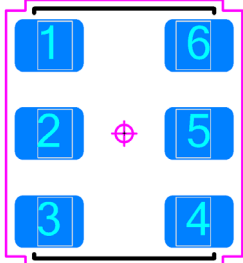
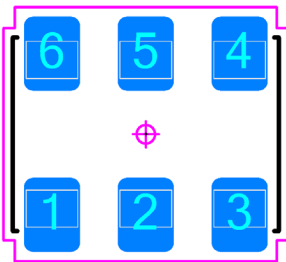
<p>Oscillator Side Concave 4-Pin</p> 	<p>Oscillator Side Concave 4-Pin Land Pattern Zero Rotation A</p> 	<p>Oscillator Side Concave 4-Pin Land Pattern Zero Rotation B</p> 
<p>Oscillator Side Concave 6-Pin</p> 	<p>Oscillator Side Concave 6-Pin Land Pattern Zero Rotation A</p> 	<p>Oscillator Side Concave 6-Pin Land Pattern Zero Rotation B</p> 

Side Concave (4-Pin) Diode and LED

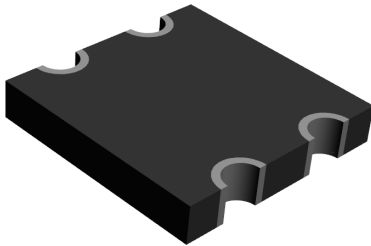
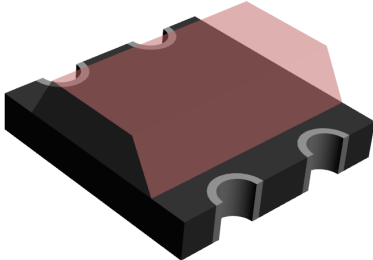
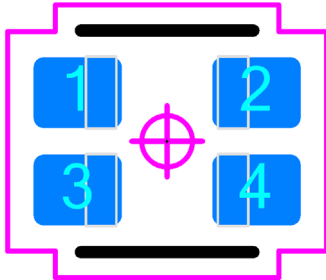
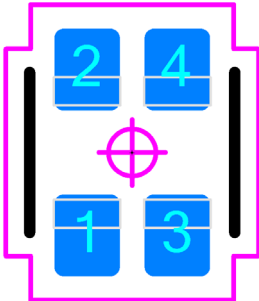
<p>Diode Side Concave 4-Pin</p> 	<p>LED Side Concave 4-Pin</p> 
<p>Diode Side Concave 4-Pin Land Pattern Zero Rotation A</p> 	<p>LED Side Concave 4-Pin Land Pattern Zero Rotation B</p> 

Side Lead Flat, Concave and Convex Terminal (unit: mm)

Side Lead
Terminal Lead Spacing
Pitch > 2.54 mm
Pitch > 1.27 and <= 2.54 mm
Pitch > 0.80 and <= 1.27 mm
Pitch > 0.65 and <= 0.80 mm
Pitch > 0.50 and <= 0.65 mm
Pitch > 0.40 and <= 0.50 mm
Pitch <= 0.40 mm

Least Density Level			
Toe	Heel	Side	Courtyard
0.45	0.02	0.00	0.10
0.40	0.00	0.00	0.10
0.35	0.00	0.00	0.10
0.25	0.00	0.00	0.10
0.20	0.00	0.00	0.10
0.15	0.00	0.00	0.10
0.10	0.00	0.00	0.10

Side Lead
Terminal Lead Spacing
Pitch > 2.54 mm
Pitch > 1.27 and <= 2.54 mm
Pitch > 0.80 and <= 1.27 mm
Pitch > 0.65 and <= 0.80 mm
Pitch > 0.50 and <= 0.65 mm
Pitch > 0.40 and <= 0.50 mm
Pitch <= 0.40 mm

Nominal Density Level			
Toe	Heel	Side	Courtyard
0.55	0.04	0.00	0.20
0.50	0.02	0.00	0.20
0.45	0.00	0.00	0.20
0.35	0.00	0.00	0.20
0.30	0.00	0.00	0.20
0.25	0.00	0.00	0.20
0.20	0.00	0.00	0.20

Side Lead
Terminal Lead Spacing
Pitch > 2.54 mm
Pitch > 1.27 and <= 2.54 mm
Pitch > 0.80 and <= 1.27 mm
Pitch > 0.65 and <= 0.80 mm
Pitch > 0.50 and <= 0.65 mm
Pitch > 0.40 and <= 0.50 mm
Pitch <= 0.40 mm

Most Density Level			
Toe	Heel	Side	Courtyard
0.65	0.06	0.01	0.40
0.60	0.04	0.00	0.40
0.55	0.02	0.00	0.40
0.45	0.00	0.00	0.40
0.40	0.00	0.00	0.40
0.35	0.00	0.00	0.40
0.30	0.00	0.00	0.40

Small Outline IC (SOIC)

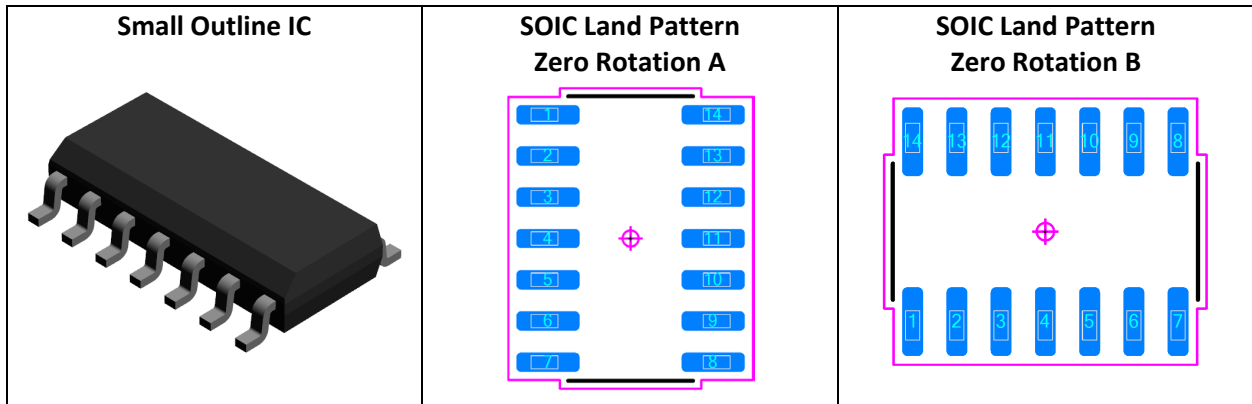

Small Outline IC (SOIC) with Thermal Tab

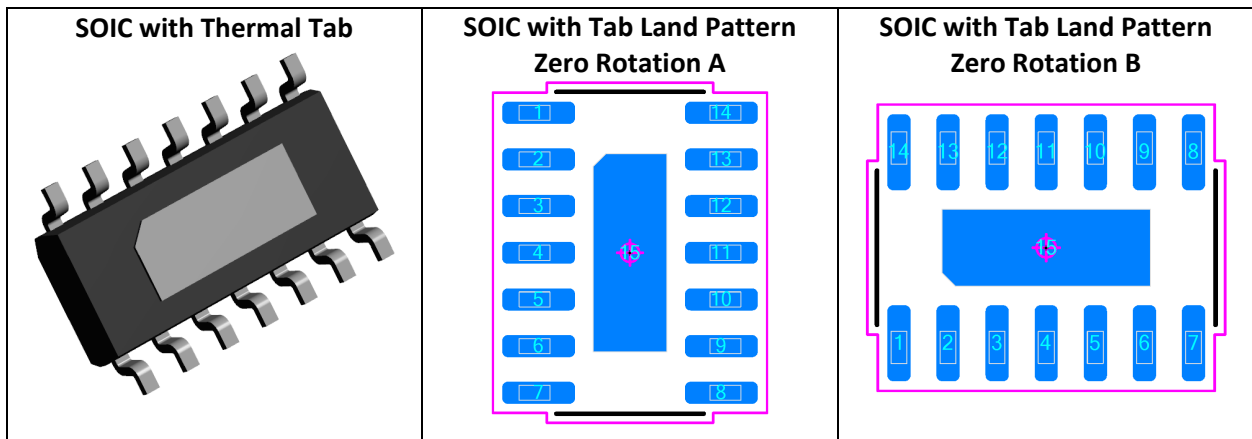

Small Outline Package (SOP)

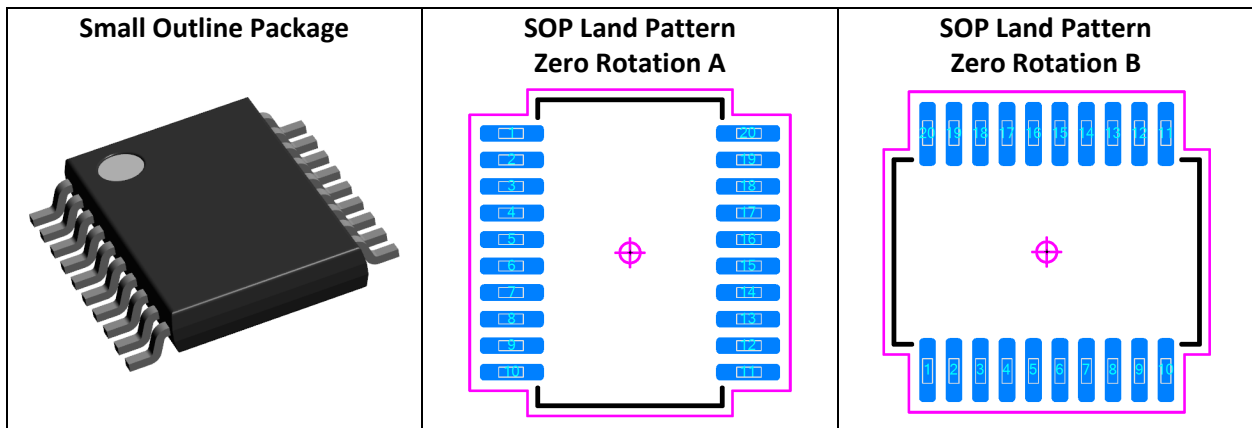

Small Outline Package (SOP) with Thermal Tab

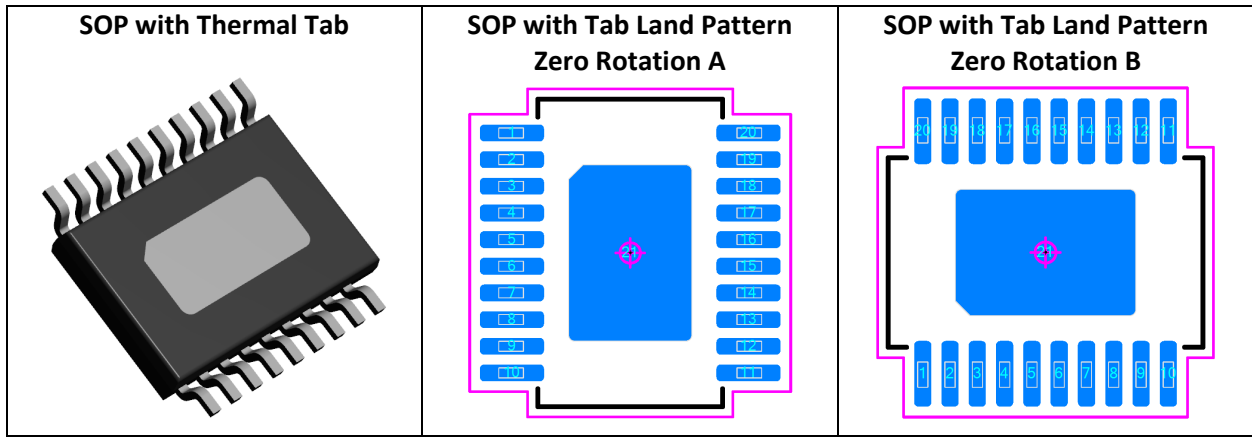

Ceramic Flat Package (CFP)

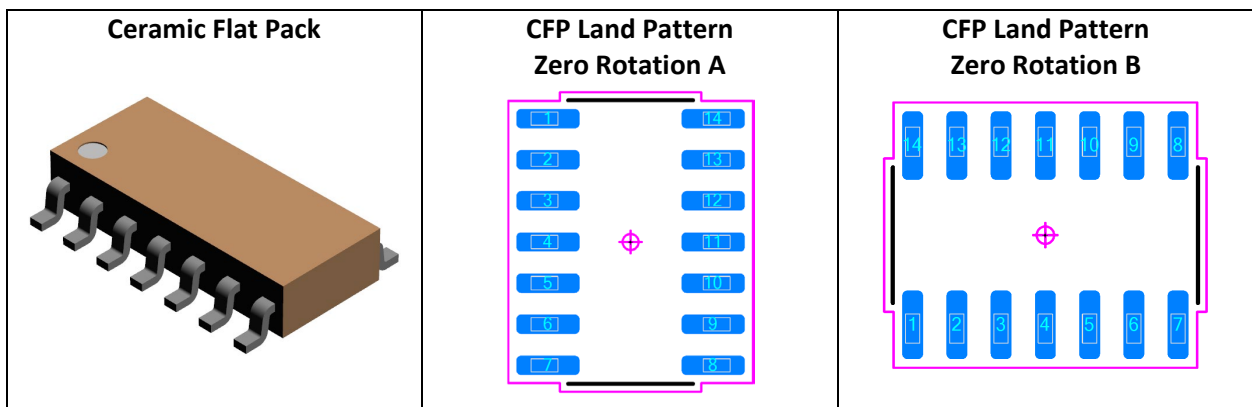

Quad Flat Package (QFP)

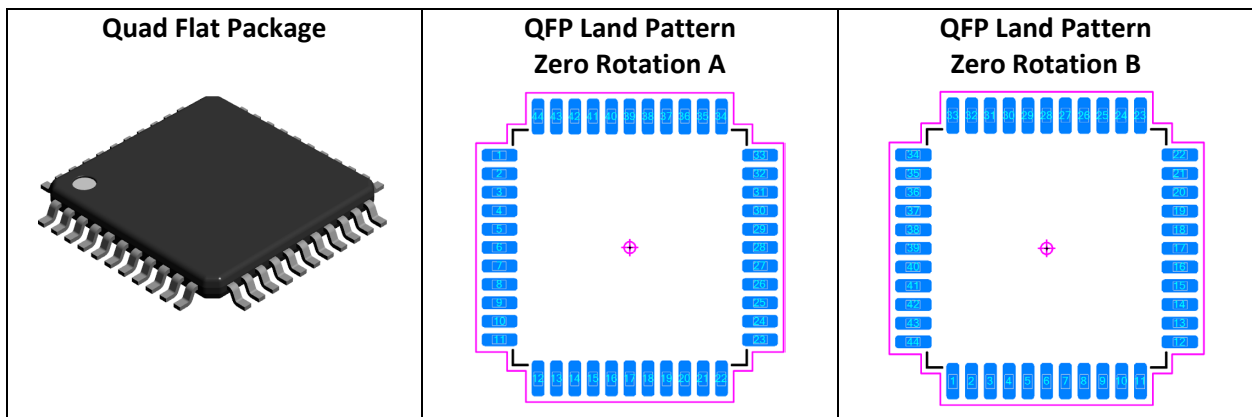

Quad Flat Package (QFP) with Thermal Tab

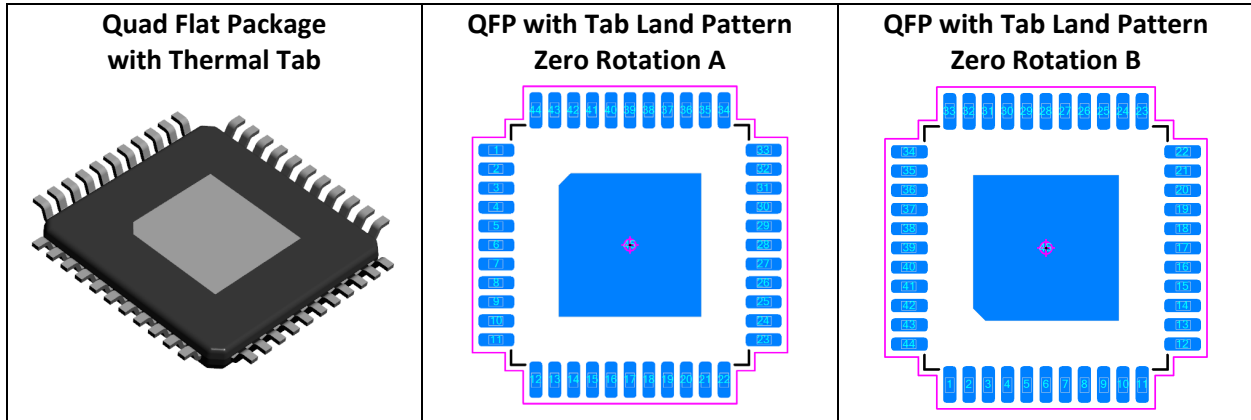

Ceramic Quad Flat Package (CQFP)

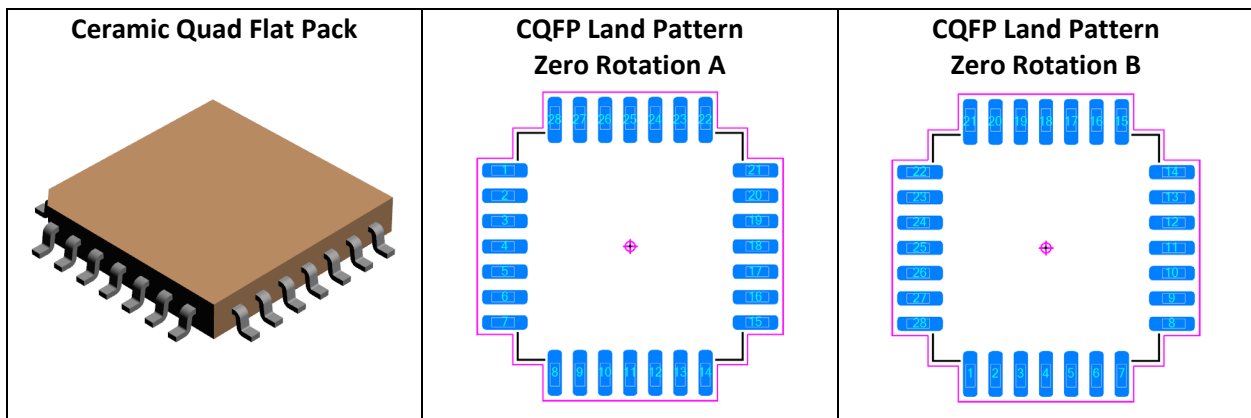

SOP / QFP Flat Ribbon L and Gull-Wing Leads (unit: mm)

SOP / QFP
Terminal Lead Spacing
Pitch > 1.00 mm
Pitch > 0.80 and <= 1.00 mm
Pitch > 0.65 and <= 0.80 mm
Pitch > 0.50 and <= 0.65 mm
Pitch > 0.40 and <= 0.50 mm
Pitch <= 0.40 mm

Least Density Level			
Toe	Heel	Side	Courtyard
0.30	0.40	0.05	0.10
0.25	0.35	0.04	0.10
0.20	0.30	0.03	0.10
0.15	0.25	0.01	0.10
0.10	0.20	0.00	0.10
0.10	0.20	0.00	0.10

SOP / QFP
Terminal Lead Spacing
Pitch > 1.00 mm
Pitch > 0.80 and <= 1.00 mm
Pitch > 0.65 and <= 0.80 mm
Pitch > 0.50 and <= 0.65 mm
Pitch > 0.40 and <= 0.50 mm
Pitch <= 0.40 mm

Nominal Density Level			
Toe	Heel	Side	Courtyard
0.35	0.45	0.06	0.20
0.30	0.40	0.05	0.20
0.25	0.35	0.04	0.20
0.20	0.30	0.02	0.20
0.15	0.25	0.00	0.20
0.15	0.25	0.00	0.20

SOP / QFP
Terminal Lead Spacing
Pitch > 1.00 mm
Pitch > 0.80 and <= 1.00 mm
Pitch > 0.65 and <= 0.80 mm
Pitch > 0.50 and <= 0.65 mm
Pitch > 0.40 and <= 0.50 mm
Pitch <= 0.40 mm

Most Density Level			
Toe	Heel	Side	Courtyard
0.40	0.50	0.07	0.40
0.35	0.45	0.06	0.40
0.30	0.40	0.05	0.40
0.25	0.35	0.03	0.40
0.20	0.30	0.00	0.40
0.20	0.30	0.00	0.40

Small Outline J-Lead (SOJ)

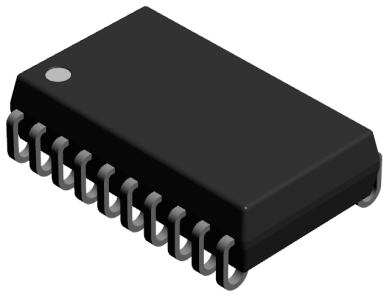
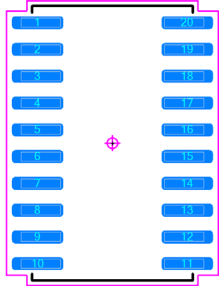
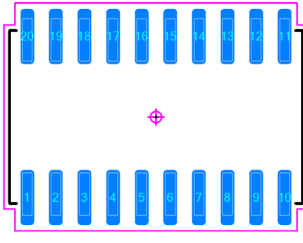
<p>Small Outline J-Lead</p> 	<p>SOJ Land Pattern Zero Rotation A</p> 	<p>SOJ Land Pattern Zero Rotation B</p> 
------------------------------------------------------------------------------------------------------------------------	------------------------------------------------------------------------------------------------------------------------------------	--------------------------------------------------------------------------------------------------------------------------------------

Plastic Leaded Chip Carrier (PLCC)

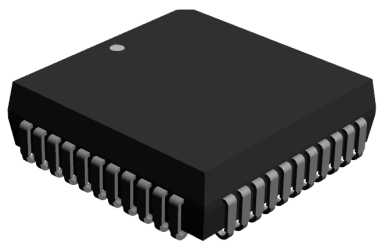
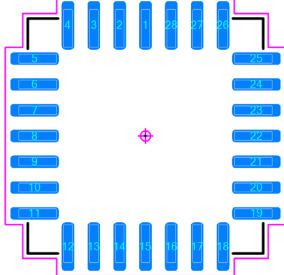
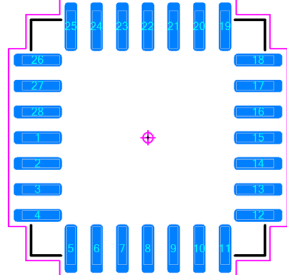
<p>Plastic Leaded Chip Carrier</p> 	<p>PLCC Land Pattern Zero Rotation A</p> 	<p>PLCC Land Pattern Zero Rotation B</p> 
-------------------------------------------------------------------------------------------------------------------------------	-------------------------------------------------------------------------------------------------------------------------------------	---------------------------------------------------------------------------------------------------------------------------------------

Small Outline J-Lead (unit: mm)

Lead Part	Most Density Level A	Nominal Density Level B	Least Density Level C
Heel (J_H) (to find Z dim)	0.55	0.35	0.15
Toe (J_T) (to find G dim)	0.10	0.00	0.00
Side (J_S)	0.05	0.03	0.01
Round-off factor	Round off to the nearest two place decimal, i.e., 1.00, 1.01, 1.02, 1.03		
Courtyard excess	0.40	0.20	0.10

Small Outline L-Lead (SOL)

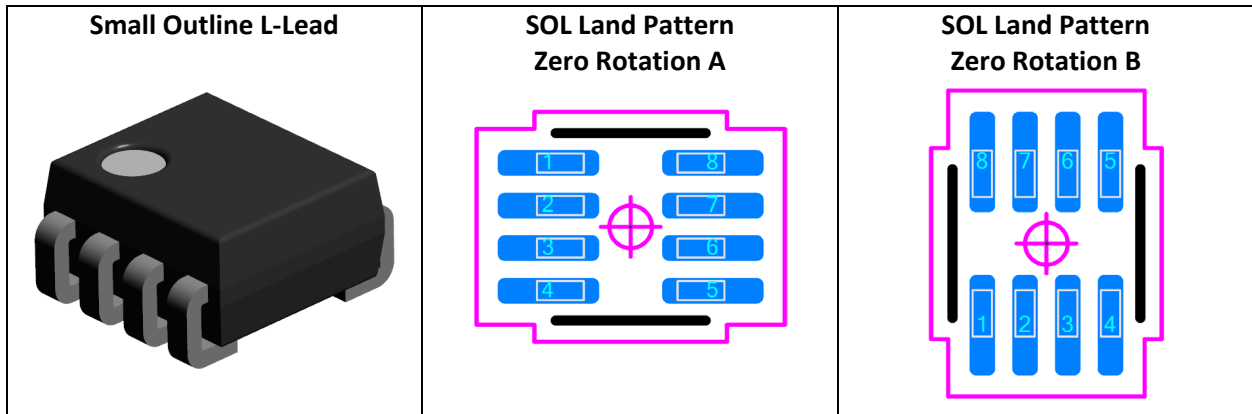

Small Outline Inward L-Lead (SOL) (unit: mm)

Inward L
Terminal Lead Spacing
Pitch > 1.00 mm
Pitch > 0.80 and <= 1.00 mm
Pitch > 0.65 and <= 0.80 mm
Pitch > 0.50 and <= 0.65 mm
Pitch > 0.40 and <= 0.50 mm
Pitch <= 0.40 mm

Least Density Level			
Toe	Heel	Side	Courtyard
0.00	0.40	0.05	0.10
0.00	0.35	0.04	0.10
0.00	0.30	0.03	0.10
0.00	0.25	0.01	0.10
0.00	0.20	0.00	0.10
0.00	0.15	0.00	0.10

Inward L
Terminal Lead Spacing
Pitch > 1.00 mm
Pitch > 0.80 and <= 1.00 mm
Pitch > 0.65 and <= 0.80 mm
Pitch > 0.50 and <= 0.65 mm
Pitch > 0.40 and <= 0.50 mm
Pitch <= 0.40 mm

Nominal Density Level			
Toe	Heel	Side	Courtyard
0.00	0.50	0.06	0.20
0.00	0.45	0.05	0.20
0.00	0.40	0.04	0.20
0.00	0.35	0.02	0.20
0.00	0.30	0.00	0.20
0.00	0.25	0.00	0.20



Inward L
Terminal Lead Spacing
Pitch > 1.00 mm
Pitch > 0.80 and <= 1.00 mm
Pitch > 0.65 and <= 0.80 mm
Pitch > 0.50 and <= 0.65 mm
Pitch > 0.40 and <= 0.50 mm
Pitch <= 0.40 mm

Most Density Level			
Toe	Heel	Side	Courtyard
0.10	0.60	0.07	0.40
0.10	0.55	0.06	0.40
0.10	0.50	0.05	0.40
0.10	0.45	0.03	0.40
0.10	0.40	0.00	0.40
0.10	0.35	0.00	0.40

Ball Grid Array, Collapsing Ball (BGA)

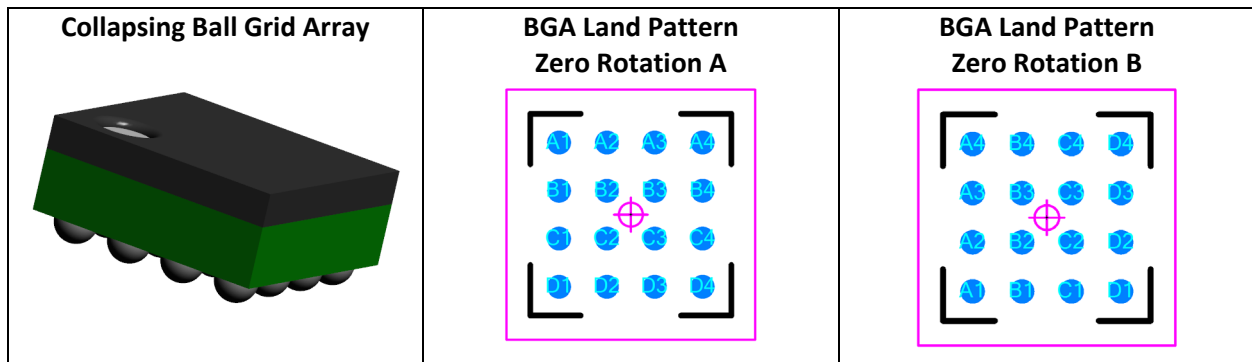

Collapsing Ball Grid Array (BGA) (unit: mm)

Collapsing Ball Grid Array (BGA)				
Nominal Ball Diameter	Ball Size Reduction	Finished Land Diameter	Density Level	Courtyard
0.75	15%	0.65	A	1.00
0.65	15%	0.55	A	1.00
0.60	15%	0.50	A	1.00
0.55	15%	0.47	A	1.00
0.50	10%	0.45	B	0.50
0.45	10%	0.40	B	0.50
0.40	10%	0.36	B	0.50
0.35	10%	0.32	B	0.50
0.30	10%	0.27	B	0.50
0.25	10%	0.23	B	0.50
0.20	0%	0.20	C	0.25
0.17	0%	0.17	C	0.25
0.15	0%	0.15	C	0.25

Ball Grid Array, Non-collapsing Ball (BGAN)

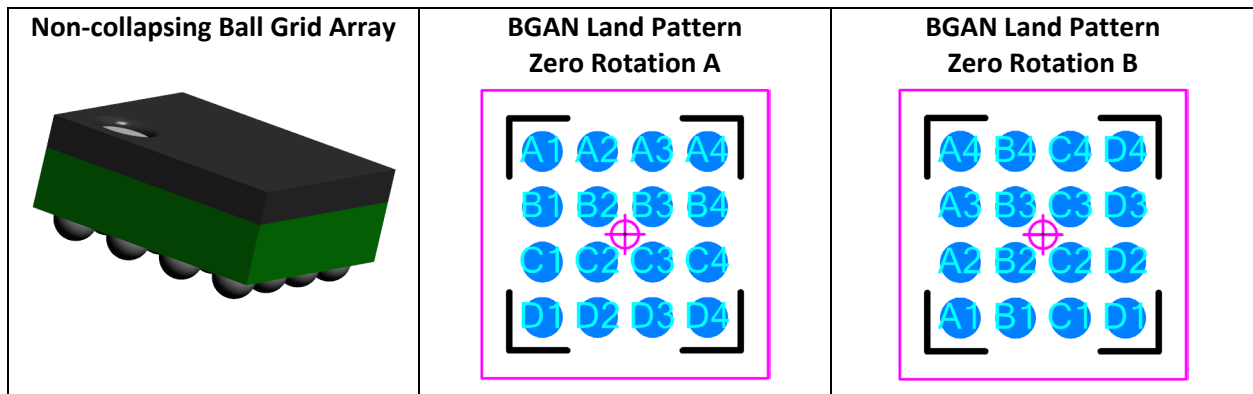

Non-collapsing Ball Grid Array (BGAN) (unit: mm)

Non-collapsing Ball Grid Array (BGAN)				
Nominal Ball Diameter	Ball Size Increase	Finished Land Diameter	Density Level	Courtyard
0.75	20%	0.90	A	1.00
0.65	20%	0.78	A	1.00
0.60	20%	0.72	A	1.00
0.55	20%	0.66	A	1.00
0.50	15%	0.58	B	0.50
0.45	15%	0.52	B	0.50
0.40	15%	0.46	B	0.50
0.35	15%	0.40	B	0.50
0.30	15%	0.35	B	0.50
0.25	15%	0.29	B	0.50
0.20	10%	0.22	C	0.25
0.17	10%	0.19	C	0.25
0.15	10%	0.17	C	0.25

Column Grid Array (CGA)

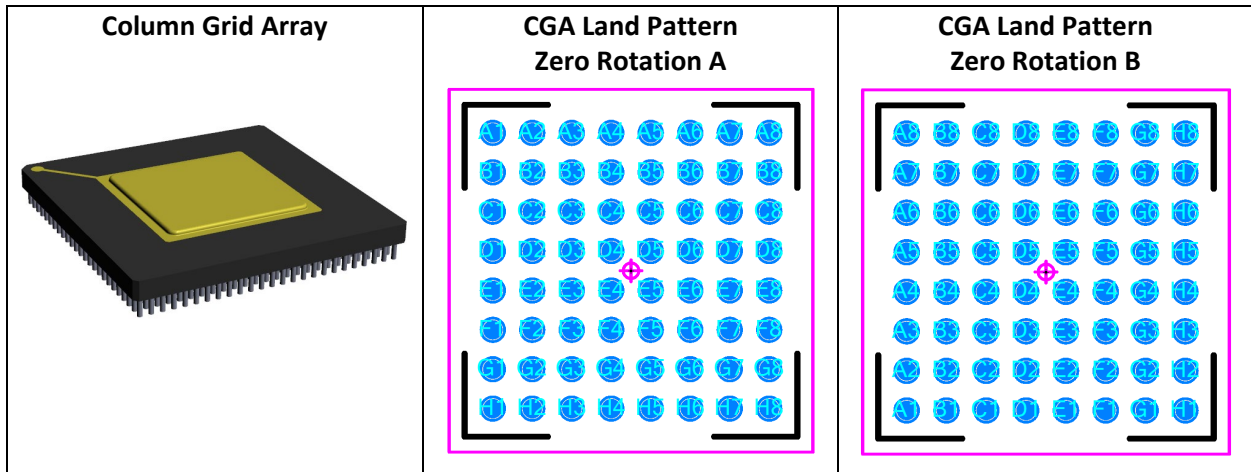

Column Grid Array (CGA)

Lead Part	Most Density Level A	Nominal Density Level B	Least Density Level C
Periphery	0.15	0.10	0.05
Round-off factor	Round off to the nearest two place decimal, i.e., 1.00, 1.01, 1.02, 1.03		
Courtyard excess	1.50	1.00	0.50

Small Outline No-lead (SON)

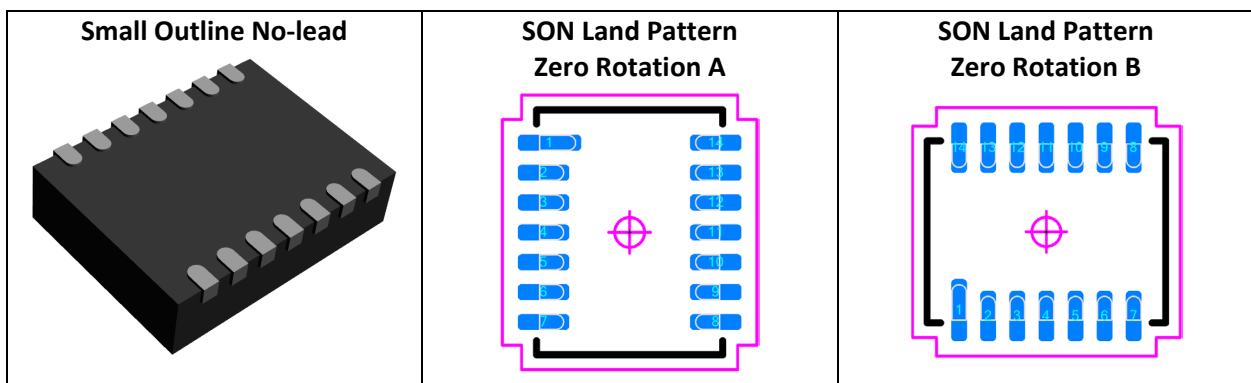

Small Outline No-lead (SON) with Thermal Tab

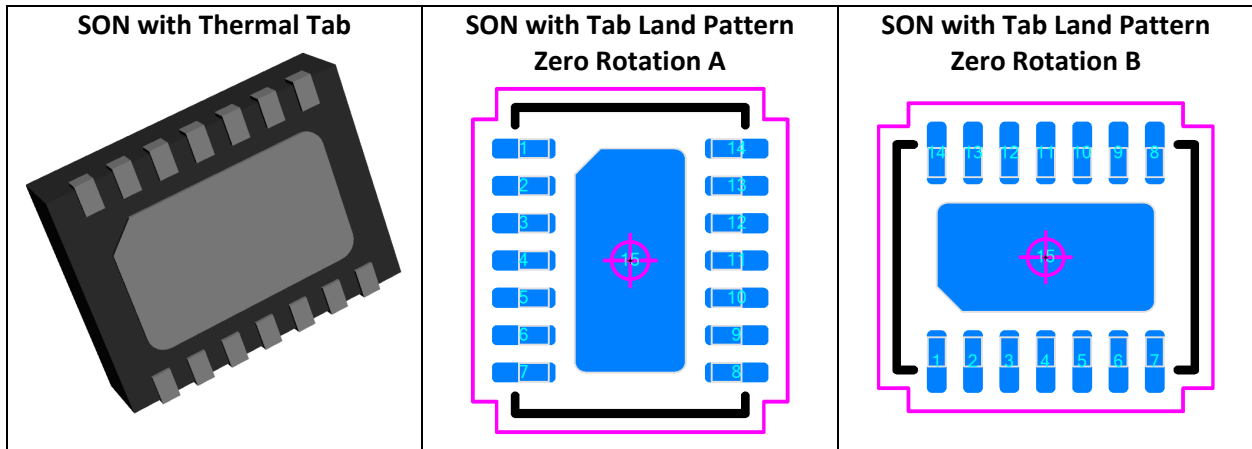

Quad Flat No-lead (QFN)

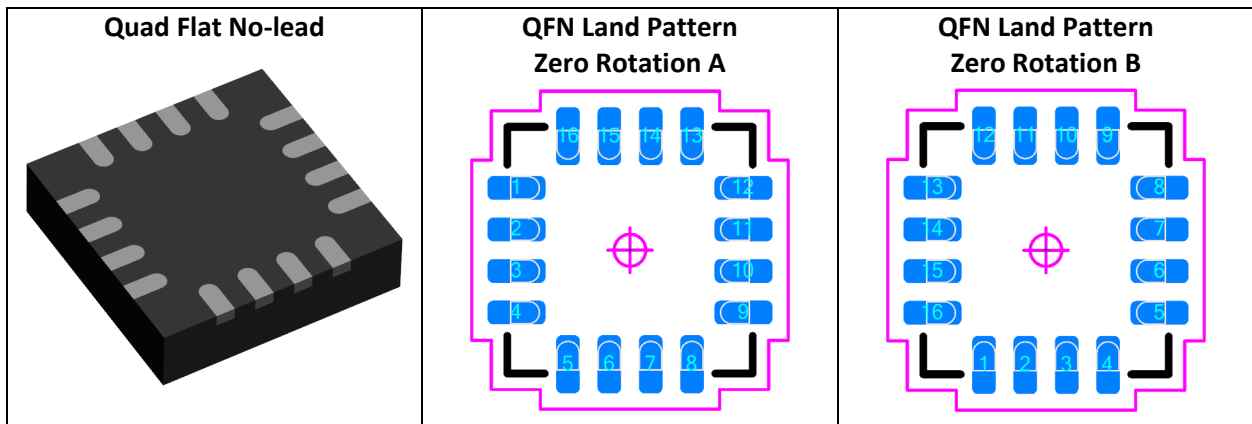

Quad Flat No-lead (QFN) with Thermal Tab

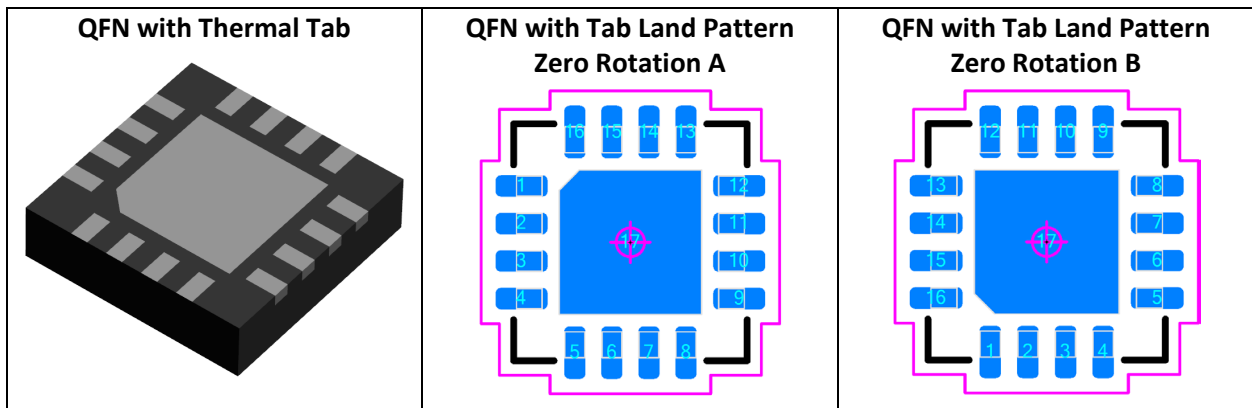

Small Outline No-Lead and Quad Flat No-Lead (unit: mm)

Lead Part	Most Density Level A	Nominal Density Level B	Least Density Level C
Toe (J_T)	0.30	0.20	0.10
Heel (J_H)	0.00	0.00	0.00
Side (J_S)	0.00	0.00	0.00
Round-off factor	Round off to the nearest two place decimal, i.e., 1.00, 1.01, 1.02, 1.03		
Courtyard excess	0.40	0.20	0.10

Pull-back Small Outline No-lead (PSON)

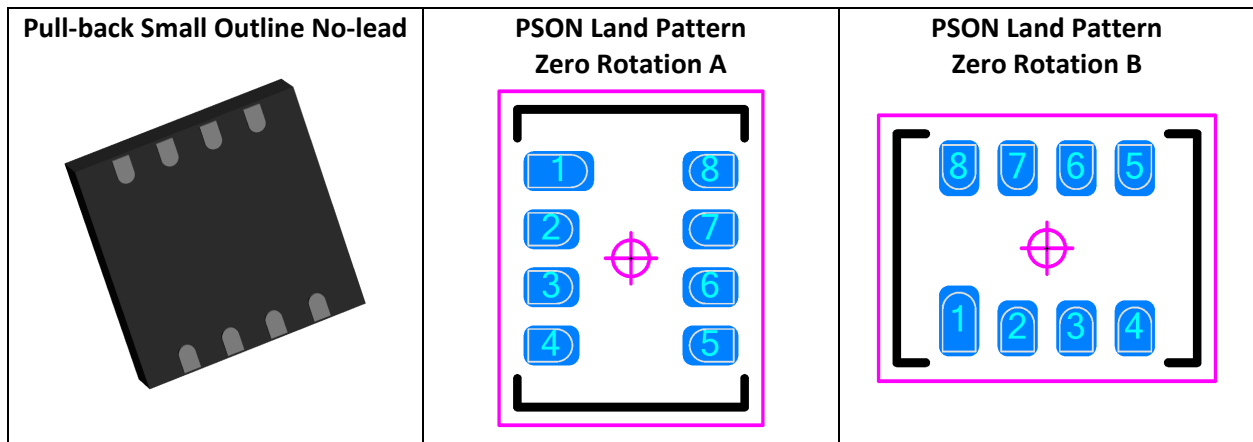

Pull-back Small Outline No-lead (PSON) with Thermal Tab

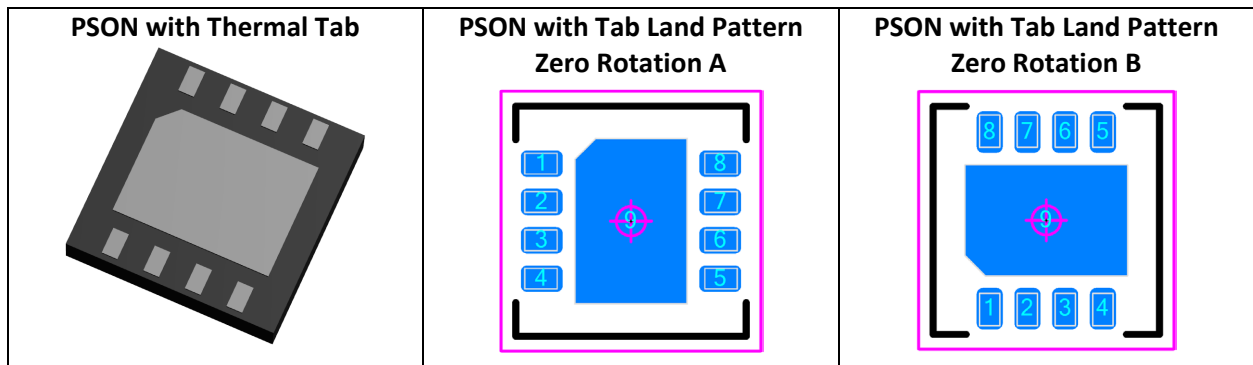

Pull-back Quad Flat No-lead (PQFN)

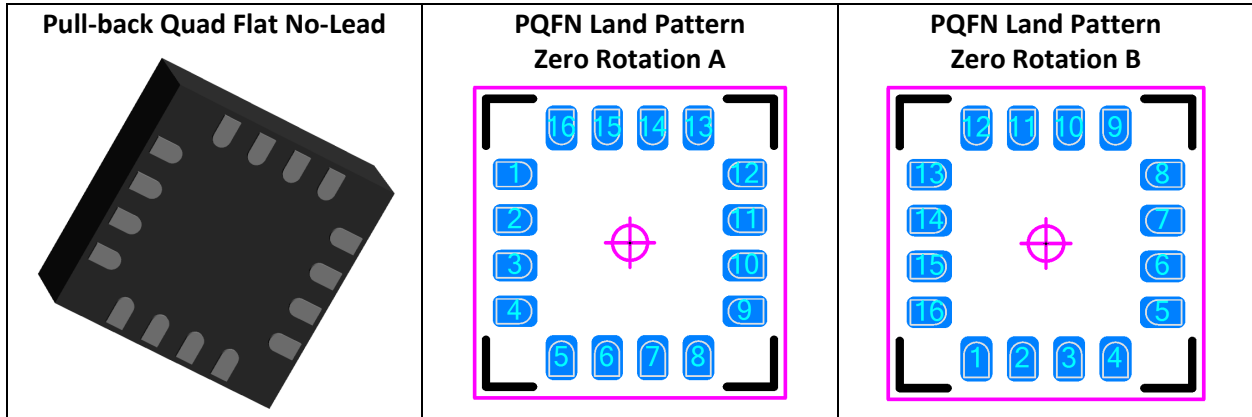

Pull-back Quad Flat No-lead (PQFN) with Thermal Tab

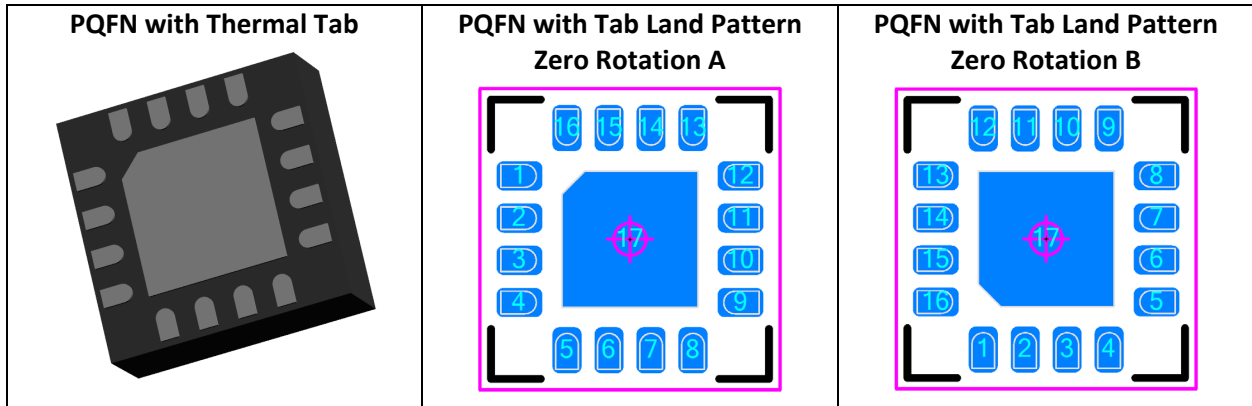

Small Outline No-Lead and Quad Flat No-Lead with Pullback (unit: mm)

Lead Part	Most Density Level A	Nominal Density Level B	Least Density Level C
Periphery	0.05	0.00	0.00
Round-off factor	Round off to the nearest two place decimal, i.e., 1.00, 1.01, 1.02, 1.03		
Courtyard excess	0.40	0.20	0.10
Dual Flat No-Lead (DFN) Less than 1608 (0603)			
Periphery	0.00	0.00	0.00
Round-off factor	Round off to the nearest two place decimal, i.e., 1.00, 1.01, 1.02, 1.03		
Courtyard excess	0.20	0.15	0.10

Land Grid Array (LGA)

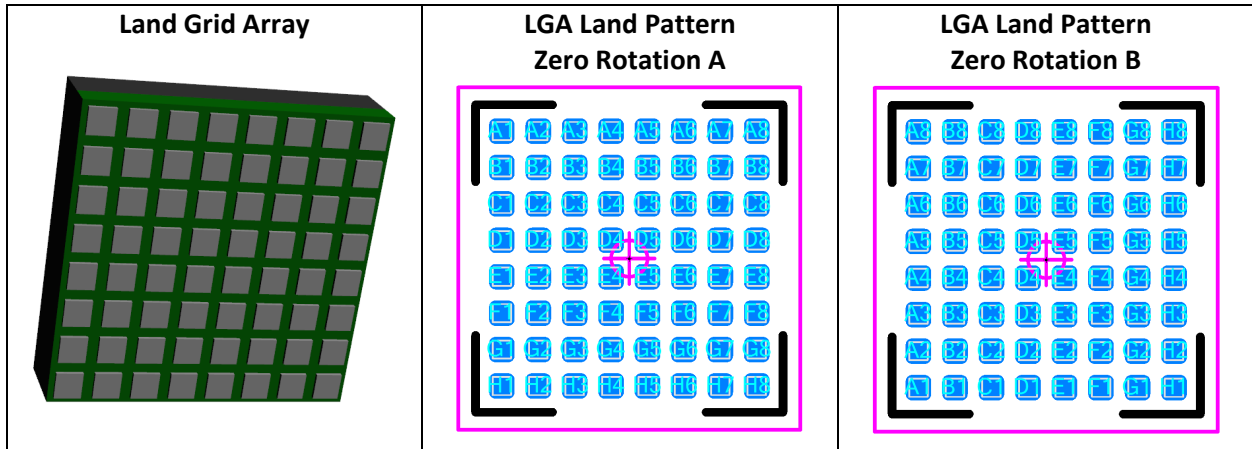

Land Grid Array (LGA) (unit: mm)

Lead Part	Maximum (Most) Density Level A	Median (Nominal) Density Level B	Minimum (Least) Density Level C
Periphery	0.05	0.00	0.00
Round-off factor	Round off to the nearest two place decimal, i.e., 1.00, 1.01, 1.02, 1.03		
Courtyard excess	0.40	0.20	0.10

Leadless Chip Carrier (LCC)

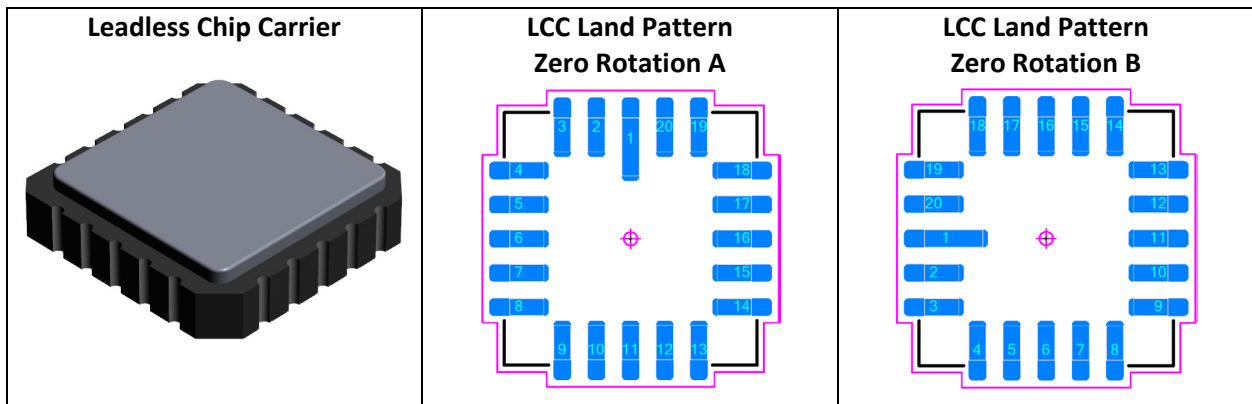

Leadless Chip Carrier (LCC) (unit: mm)

Lead Part	Most Density Level A	Nominal Density Level B	Least Density Level C
Heel (J_H) (to find Z dim)	0.06	0.04	0.02
Toe (J_T) (to find G dim)	0.60	0.50	0.40
Side (J_S)	0.00	0.00	0.00
Round-off factor	Round off to the nearest two place decimal, i.e., 1.00, 1.05, 1.10, 1.15		
Courtyard excess	0.40	0.20	0.10

Resistor, Side Concave Chip Array (RESCAV)

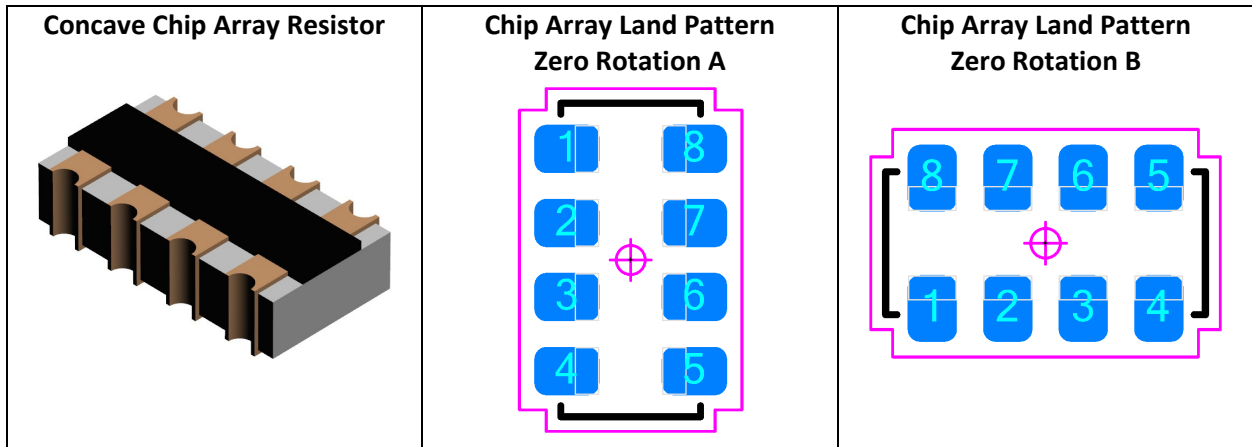

Inductor, Side Flat Chip Array (INDCAV)

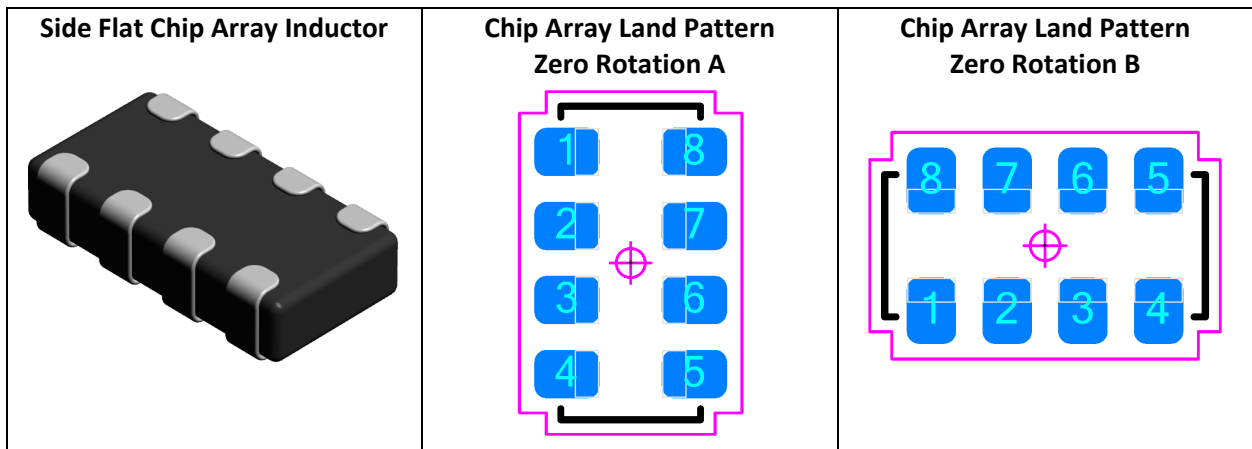

Resistor, Side Concave Chip Array 4-Sided (RESCAV)

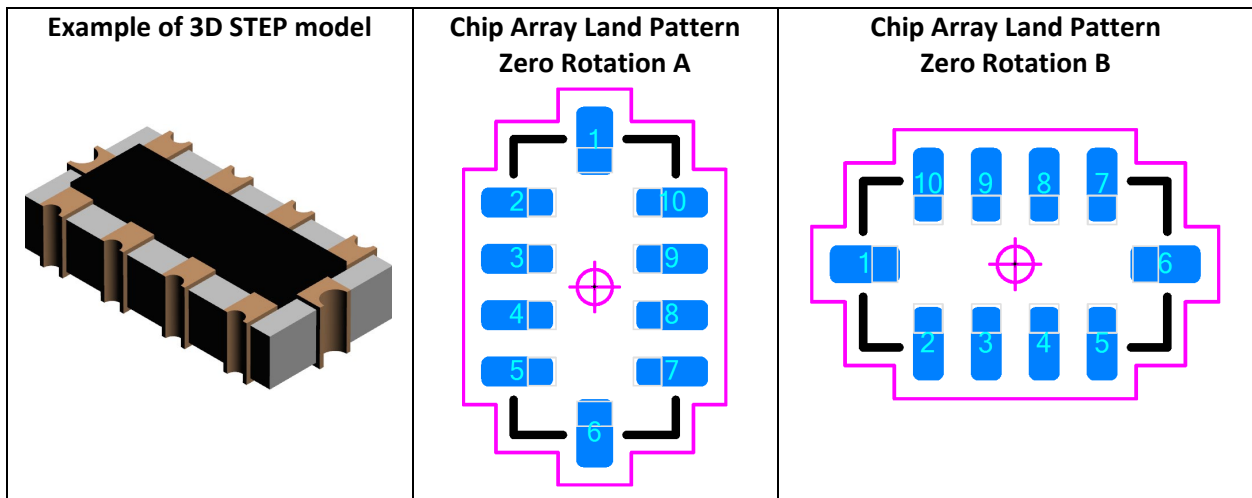

Resistor, Convex Chip Array Type E (RESCAXE)

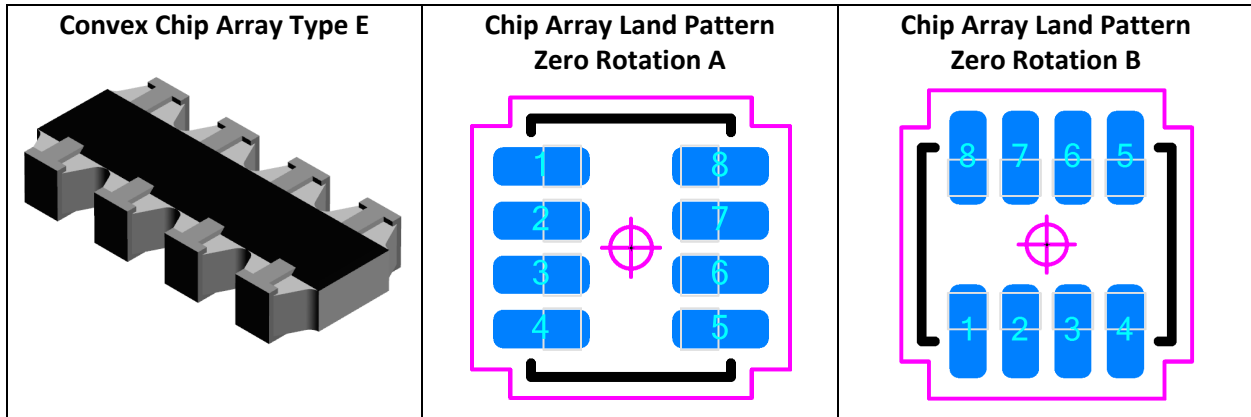

Resistor, Convex Chip Array Type S (RESCAXS)

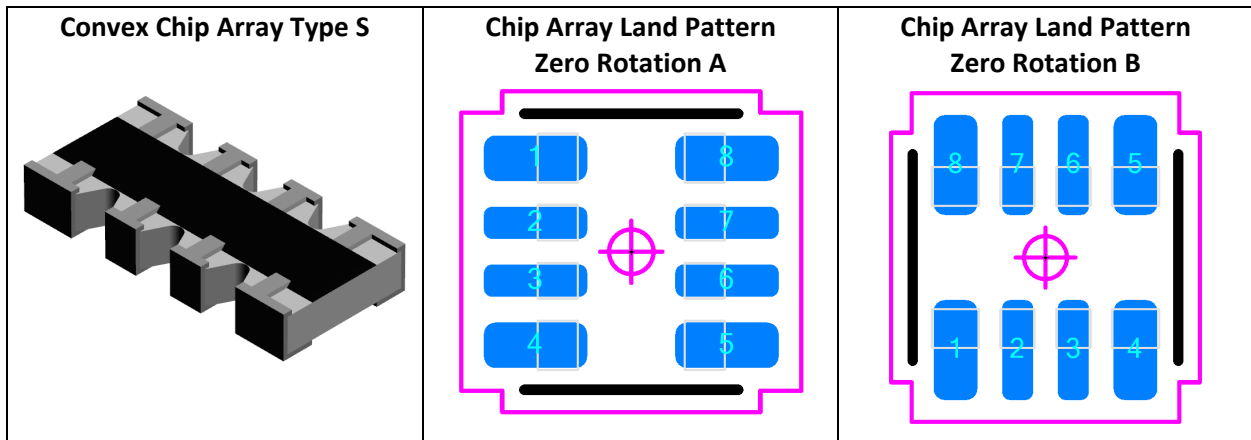

Side Flat/Concave/Convex Terminals (unit: mm)

Side Lead
Terminal Lead Spacing
Pitch > 2.54 mm
Pitch > 1.27 and <= 2.54 mm
Pitch > 0.80 and <= 1.27 mm
Pitch > 0.65 and <= 0.80 mm
Pitch > 0.50 and <= 0.65 mm
Pitch > 0.40 and <= 0.50 mm
Pitch <= 0.40 mm

Least Density Level			
Toe	Heel	Side	Courtyard
0.45	0.02	0.00	0.10
0.40	0.00	0.00	0.10
0.35	0.00	0.00	0.10
0.25	0.00	0.00	0.10
0.20	0.00	0.00	0.10
0.15	0.00	0.00	0.10
0.10	0.00	0.00	0.10

Side Lead
Terminal Lead Spacing
Pitch > 2.54 mm
Pitch > 1.27 and <= 2.54 mm
Pitch > 0.80 and <= 1.27 mm
Pitch > 0.65 and <= 0.80 mm
Pitch > 0.50 and <= 0.65 mm
Pitch > 0.40 and <= 0.50 mm
Pitch <= 0.40 mm

Nominal Density Level			
Toe	Heel	Side	Courtyard
0.55	0.04	0.00	0.20
0.50	0.02	0.00	0.20
0.45	0.00	0.00	0.20
0.35	0.00	0.00	0.20
0.30	0.00	0.00	0.20
0.25	0.00	0.00	0.20
0.20	0.00	0.00	0.20

Side Lead
Terminal Lead Spacing
Pitch > 2.54 mm
Pitch > 1.27 and <= 2.54 mm
Pitch > 0.80 and <= 1.27 mm
Pitch > 0.65 and <= 0.80 mm
Pitch > 0.50 and <= 0.65 mm
Pitch > 0.40 and <= 0.50 mm
Pitch <= 0.40 mm

Most Density Level			
Toe	Heel	Side	Courtyard
0.65	0.06	0.01	0.40
0.60	0.04	0.00	0.40
0.55	0.02	0.00	0.40
0.45	0.00	0.00	0.40
0.40	0.00	0.00	0.40
0.35	0.00	0.00	0.40
0.30	0.00	0.00	0.40

Component Terminal Lead-Forms

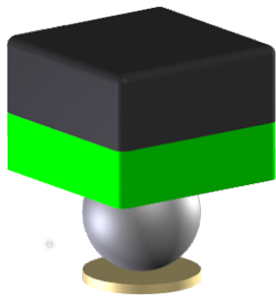

Ball Grid Array

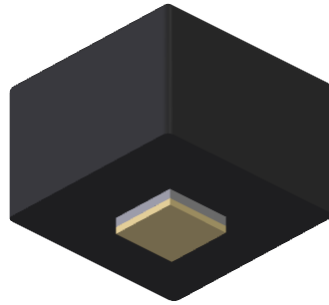

Land Grid Array/Bottom Only



Column Grid Array

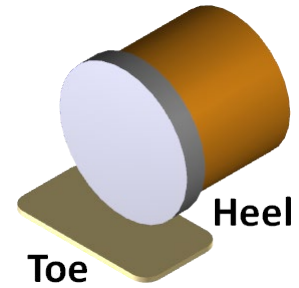

Toe Heel

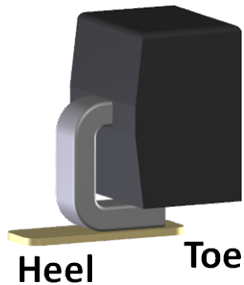

Heel Toe

Inward L Lead



Heel Toe

Outward L Lead

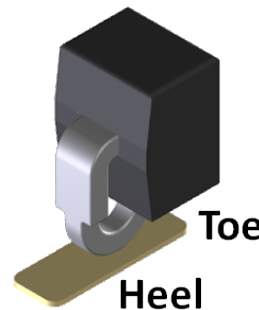

Toe Heel

J-Lead

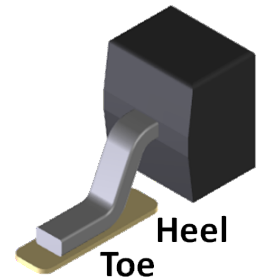

Heel Toe

Gull Wing

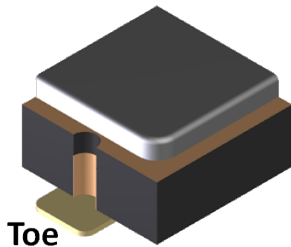

Toe

Side Concave

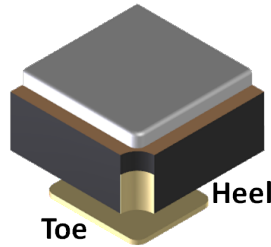

Toe

Corner Concave

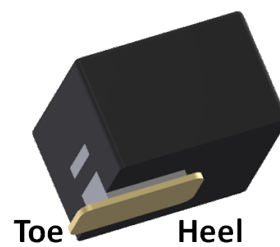

Toe

Heel

Flat No-Lead Side

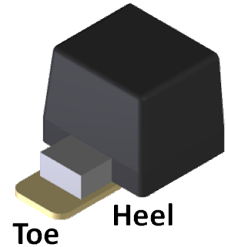

Toe

Heel

Flat Lead

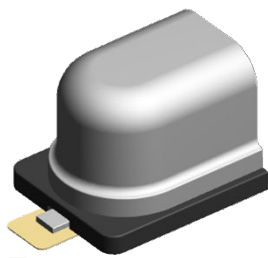

Toe

Under Body Outward L

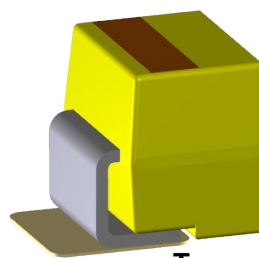

Heel

Toe

Inward Flat Ribbon L

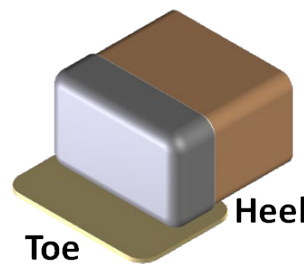

Toe

Heel

Rectangular End Cap

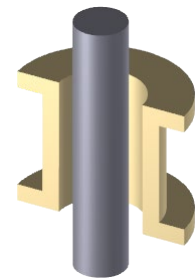

Through-Hole

Polarity Marking Legend

The goal of the Polarity Marking Legend is to aid assembly to avoid polarized component packages from being inverted during the assembly machine setup or manual solder process. Therefore, Polarity Marking is only necessary on land patterns that require a specific rotation during the assembly process. For very dense part placements, the polarity marker can be placed under the package and covered up during the assembly process. However, the best practice is to locate the polarity indicator outside the package so that it is visible after the assembly process to allow the end user to visually validate that the assembly insertion process is correct. This is typically known as “Post Assembly Inspection Process”.

Polarity Markings are unique from company to company. Here are samples of the most popular shapes.



The size, rotation and location of the Polarity Markings are user definable. Here are some recommendations.

The most popular polarity marking is a filled Dot. The size of the Polarity Marking is relevant to the size of the component package and pad width. However, the polarity dot size is also dependent on the part placement density and the assembly shops ability to easily locate the dot to avoid component rotation insertion errors. The smallest visible markings range from 0.25 mm – 0.40 mm and are typically used for micro-miniature packages or very dense part placement PCB layouts. The average size ranges are 0.50 mm – 0.80 mm. The largest recommended polarity dot is 1.00 mm.

This illustration indicates 3 popular locations for a 0.50 mm dot on an SOP package. The preferred polarity dot placement is at the end of the pad which is the furthest distance from the component package body. This makes the post assembly inspection process easy as the component package may move up or down during assembly reflow, but the dot will always be visible. The acceptable location is the pad center, but this location is also a potential via site. It is advisable to keep legend ink off non-tented vias or tented via holes. The not recommended location has a higher potential of a via site and the marking could collide with other parts during the part placement process.

Gull Wing Terminal Lead Legend Polarity Marking Location

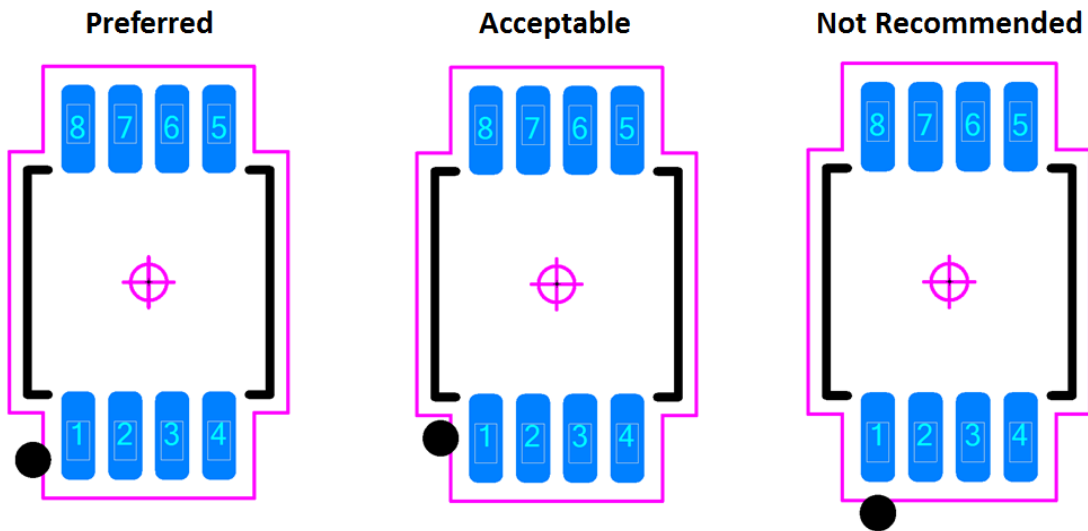

The component body outline legend line width should be a minimum of 0.125 mm. The Polarity Marking Symbol and component body legend should have a minimum 0.075 mm gap from the solder mask. The figure below illustrates the anatomy of a land pattern and feature sizes and spaces.

Sample 0.50 mm Pitch SOP Legend and Polarity Marking Rules

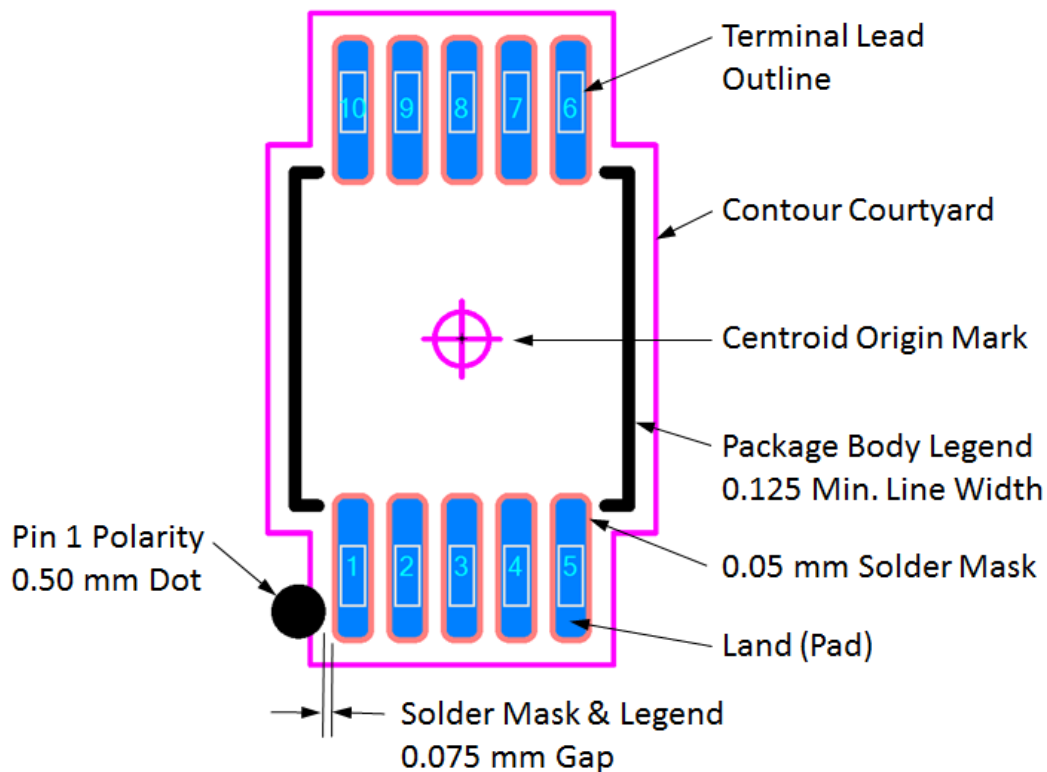

Warning, check with your PCB manufacturer to verify if they can meet the dimensional requirements.

Bottom only termination packages – BGA, LGA, CGA, QFN, PQFN, SON, PSON and DFN

The polarity marking size should match the Terminal Width. The gap between the body legend and the polarity marker should range from 0.15 mm – 0.25 mm

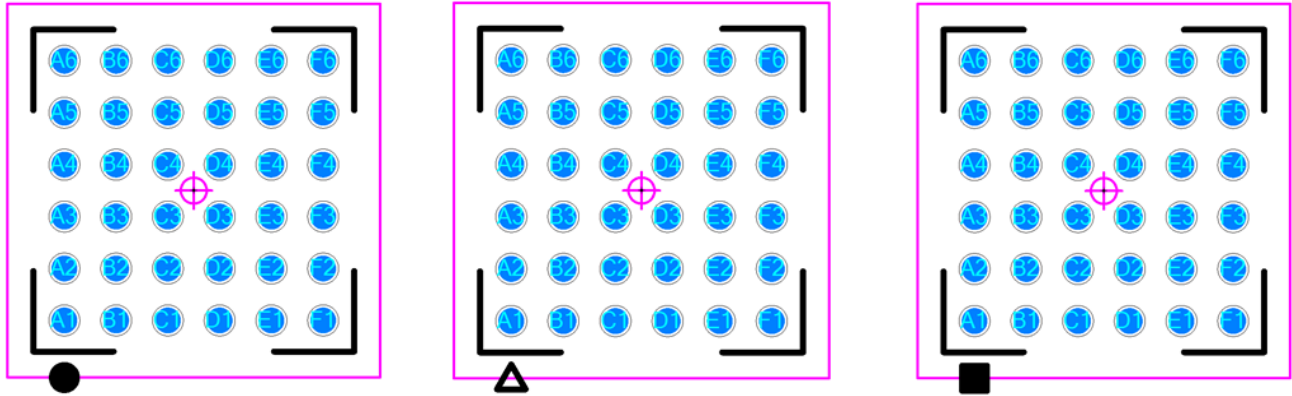

Polarized chip capacitors packages.

